

SBT

JIS B 6339

PRECISION TOOL HOLDERS SYSTEM



SBT 数控刀柄系列

CNC TOOL SYSTEMS

两面定位系统

SBT 两面定位主轴系统

SBT SPINDLE SYSTEM

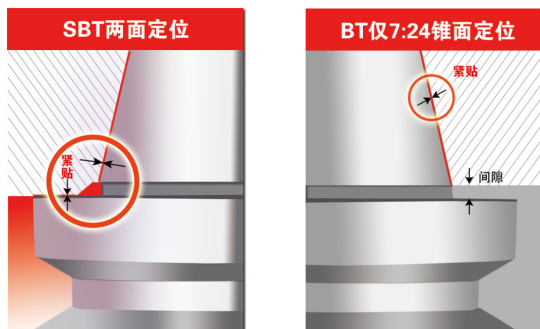

- 通过确立完善的量规系统，实现了锥面、端面同时两面定位的系统。



SBT 刀柄的各种优点:

- **提高**加工表面光洁度和加工尺寸精度
- **延长**刀具寿命
- **高刚性** 适合重切削
- **提高** ATC 自动换刀的重复精度
- 高速旋转时 Z 轴方向尺寸**稳定**
- **提高**镗孔加工的圆度

拉入量对于端面紧贴很重要!!

刀柄在未被拉紧时，与主轴端面有微小间隙。通过拉紧装置拉入，主轴因弹性形变产生扩张，实现端面完全贴紧。因此，确保端面紧贴的拉入量非常重要。

《参考值》

主轴规格	拉紧力	拉入量
#40	800Kg	20μm
#50	2000Kg	20μm

上表中的数值仅供参考，拉入量因主轴形状及紧固机构而异。（本公司加工中心的实测值）

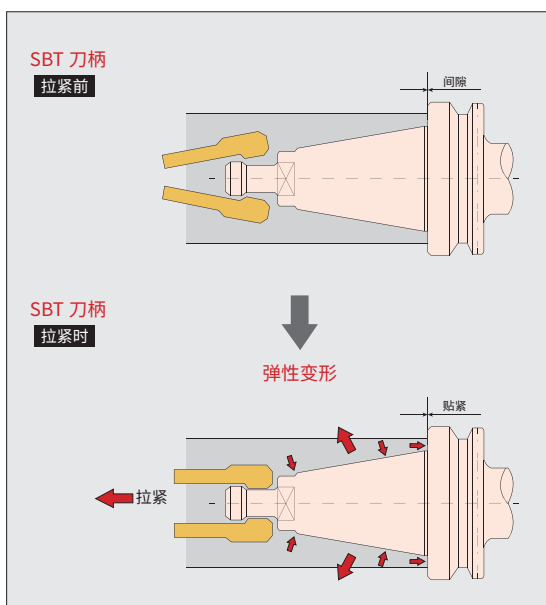

增加刀柄的基准直径，刚性增强。

根据力学原理，基准直径越大刚性越强，普通的 BT 刀柄的基准直径是锥柄的大端直径、而端面紧贴的 SBT 系统的基准直径是法兰外径。因此，SBT 刀柄刚性有了显著增强。

BT30 锥柄	φ31.75	φ46
BT40 锥柄	φ44.45	φ63
BT50 锥柄	φ69.85	φ100

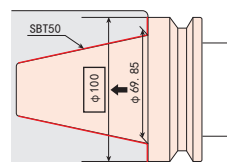

“SBT 主轴”与“SBT 刀柄”的最强组合

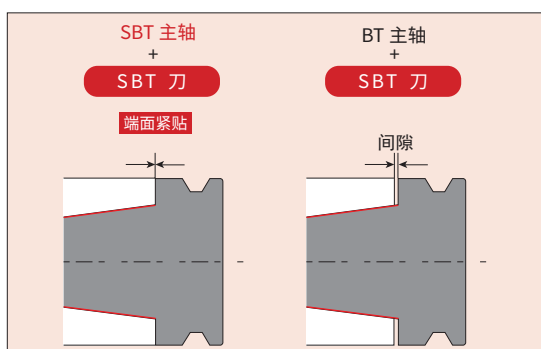

刀柄除端面位置尺寸外，其他尺寸均以 MAS-BT 规格为标准。

SBT 主轴系统通过组合 SBT 刀柄与 SBT 主轴，可最大限度地发挥两面定位的性能。SBT 刀柄也可使用原有标准规格的 BT 主轴，但这种情况下没有两面定位功能。为了发挥两面定位的优异性能，请在 SBT 主轴中使用 SBT 刀柄。另外，使用 SBT 刀柄以外的两面定位刀柄时，可能会损伤机床主轴，敬请注意。

建议在 SBT 主轴中使用 SBT 刀柄。

请勿在 SBT 主轴中混用 SBT 刀柄和 BT 刀柄。

·参考资料

REFERENCE DETAILS

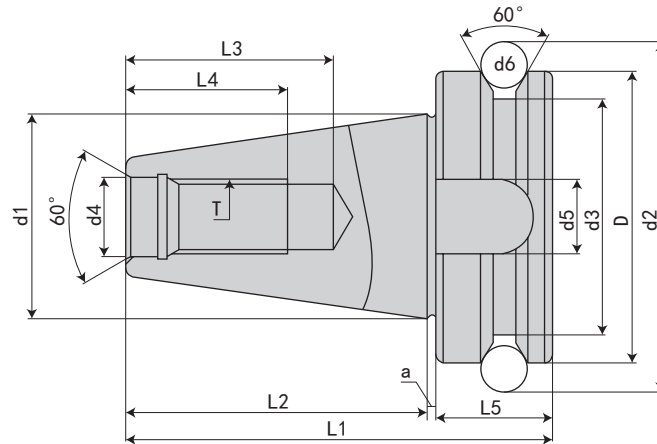

规格 Model	D h8	d1	d2	d3	d4 H8	d5 H12	d6	L1	L2 ±0.2	L3 Min	L4 Min	L5	a 0 -0.005	T 6H
SBT30	46	31.75	56.14	38	12.5	16.1	8	70.4	48.4	34	24	21	1	M12*1.75P
SBT40	63	44.45	75.679	53	17	16.1	10	92.4	65.4	43	30	26	1	M16*2.0P
SBT50	100	69.85	119.02	83	25	25.7	15	139.8	101.8	62	45	36.5	1.5	M24*3.0P

特点:

- ◎ 锥度精度: <AT3
- ◎ 基本材质: JIS-SCM415 or JIS SNCM220 or JIS SNCM439
- ◎ 硬度: HRC56°~58° 渗碳深度 >0.8mm
- ◎ 真圆度: <0.8um
- ◎ 表面粗糙度: Ra<0.5um
- ◎ 刀柄本体可另外指定: 通过 V 型法兰端出水规格 (DIN-69871-AD+B)
- ◎ ER、EOC、FMA、FMB、MLC、MLD、MLT、SCK、SFC、SKS、SLN (DIN、FID、JIS)、SOM、TG 皆符合: 通过刀柄本体中心出水规格 (DIN-69871-AD)
- ◎ 刀柄有预设标准动平衡 G6.3, 可另外指定精密动平衡 G2.5
- ◎ 本体规范: BIG-PLUS

Features:

- ◎ Taper tolerance<AT3
- ◎ Basic Material:JIS-SCM415
- ◎ Hardness>HRC 56° Carbon depth>0.8mm
- ◎ Roundness<0.8um
- ◎ Surface roughness:Ra<0.5um
- ◎ If it is suitable for center coolant standard(DIN-69871-AD or B),it can be ordered
- ◎ ER、EOC、FMA、FMB、MLC、MLD、MLT、SCK、SFC、SKS、SLN(DIN、FID、JIS)、SOM、TG Are in compliance with:Water through the chuck body center type(DIN-69871-AD)
- ◎ The shank has pre-balance at G6.3,and can provide percision balance at G2.5,made by request
- ◎ Shank body standard:BIG-PLUS

·SBT30-PHC 液压刀柄

SBT30-PHC HYDRAULIC TOOL HOLDER



FIG.1

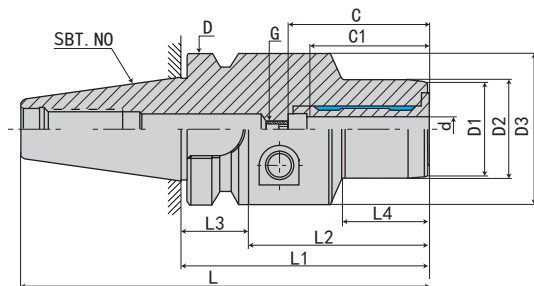
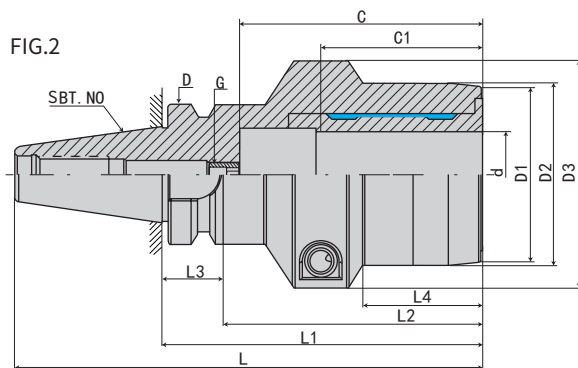

FIG.2



型号 Model	L	L1	L2	L3	L4	D	D1	D2	D3	d	最大插入深度 C Max. insertion depth	最少插入深度 C1 Min insertion depth	G	FIG	重量 KGS
SBT30-PHC03 - 60	108.4	60	38	22	28	46	20	23	45	3	*	18	*	1	0.75
-PHC3.175- 60	108.4	60	38	22	28	46	20	23	45	3.175	*	18	*	1	0.75
-PHC04- 60	108.4	60	38	22	28	46	21	24	45	4	*	24	*	1	0.75
-PHC05- 60	108.4	60	38	22	28	46	22	25	45	5	*	26	*	1	0.75
-PHC06- 70	118.4	70	48	22	28	46	23	26	45	6	37	27	M5*0.8P	1	0.8
-PHC08- 70	118.4	70	48	22	28	46	25	28	45	8	37	27	M6*1.0P	1	0.85
-PHC10- 75	123.4	75	53	22	36	46	27	30	45	10	41	31	M8*1.0P	1	0.85
-PHC12- 75	123.4	75	53	22	36	46	29	32	45	12	46	36	M10*1.0P	1	0.85
-PHC14- 85	133.4	85	63	22	44	46	31	34	45	14	46	36	M10*1.0P	1	0.95
-PHC16- 90	138.4	90	68	22	48	46	35	38	45	16	52	39	M12*1.0P	1	1.05
-PHC18- 90	138.4	90	68	22	48	46	37	40	45	18	52	39	M12*1.0P	1	1.1
-PHC20- 90	138.4	90	68	22	48	46	39	42	45	20	52	41	M16*1.0P	1	1.15
-PHC25-105	153.4	105	83	22	44	46	52	55	63	25	80	47	M16*1.0P	2	1.65
-PHC32-105	153.4	105	83	22	39	46	57	60	68	32	80	51	M16*1.0P	2	1.8

规格说明:

SBT30 - PHC - 03 - 60

- L1 长度 Length (L1)
- 刀杆直径 Diameter
- 功能代号 Holder type
- 锥柄形式 Taper size

D

 SBT SHANK SYSTEMS
 SBT 刀柄系列

·SBT40-PHC 液压刀柄

SBT40-PHC HYDRAULIC TOOL HOLDER

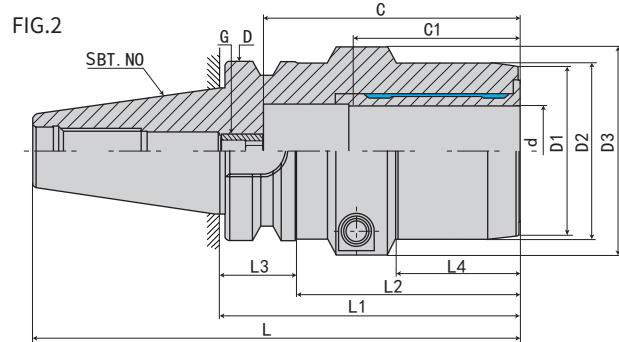
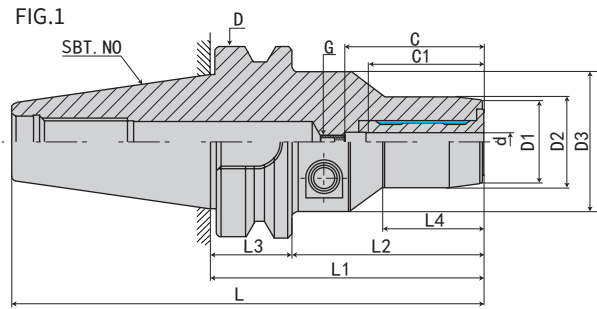

型号 Model	L	L1	L2	L3	L4	D	D1	D2	D3	d	最大插入深度 C Max. insertion depth	最少插入深度 C1 Min insertion depth	G	FIG	重量 KGS
SBT40-PHC03- 75	140.4	75	48	27	26	63	20	23	50	3	*	18	*	1	1.28
- 90	155.4	90	63	27	29	63	20	23	50	3	*	18	*	1	1.38
-PHC3.175- 75	140.4	75	48	27	26	63	20	23	50	3.175	*	18	*	1	1.28
- 90	155.4	90	63	27	29	63	20	23	50	3.175	*	18	*	1	1.38
-PHC04- 75	140.4	75	48	27	26	63	21	24	50	4	*	24	*	1	1.28
- 90	155.4	90	63	27	29	63	21	24	50	4	*	24	*	1	1.38
-PHC05- 75	140.4	75	48	27	26	63	22	25	50	5	*	26	*	1	1.3
- 90	155.4	90	63	27	29	63	22	25	50	5	*	26	*	1	1.4
-PHC06- 75	140.4	75	48	27	26	63	23	26	50	6	37	27	M5*0.8P	1	1.32
- 90	155.4	90	63	27	29	63	23	26	50	6	37	27	M5*0.8P	1	1.41
-PHC08- 75	140.4	75	48	27	26	63	25	28	50	8	37	27	M6*1.0P	1	1.36
- 90	155.4	90	63	27	30	63	25	28	50	8	37	27	M6*1.0P	1	1.46
-PHC10- 75	140.4	75	48	27	26	63	27	30	50	10	41	31	M8*1.0P	1	1.43
- 90	155.4	90	63	27	35	63	27	30	50	10	41	31	M8*1.0P	1	1.57
-PHC12- 75	140.4	75	48	27	26	63	29	32	50	12	46	36	M10*1.0P	1	1.46
- 90	155.4	90	63	27	40	63	29	32	50	12	46	36	M10*1.0P	1	1.62
-PHC14- 75	140.4	75	48	27	26	63	31	34	50	14	46	36	M10*1.0P	1	1.48
- 90	155.4	90	63	27	40	63	31	34	50	14	46	36	M10*1.0P	1	1.68
-PHC16- 75	140.4	75	48	27	26	63	35	38	50	16	75	39	M12*1.0P	1	1.51
- 90	155.4	90	63	27	45	63	35	38	50	16	75	39	M12*1.0P	1	1.7
-PHC18- 75	140.4	75	48	27	26	63	37	40	50	18	75	39	M12*1.0P	1	1.51
- 90	155.4	90	63	27	46	63	37	40	50	18	75	39	M12*1.0P	1	1.7
-PHC20- 75	140.4	75	48	27	26	63	39	42	50	20	80	41	M16*1.0P	1	1.52
- 90	155.4	90	63	27	47	63	39	42	50	20	80	41	M16*1.0P	1	1.75
-PHC25-105	170.4	105	78	27	50	63	52	55	63	25	80	47	M16*1.0P	1	2.05
-PHC32-105	170.4	105	78	27	48	63	60	63	73	32	90	51	M16*1.0P	2	2.34
-PHC40-120	185.4	120	93	27		63				40	90		M16*1.0P	2	3
-PHC42-120	185.4	120	93	27		63				42	90		M16*1.0P	2	3

规格说明:

SBT40 - PHC - 03 - 75

- L1 长度 Length (L1)
- 刀杆直径 Diameter
- 功能代号 Holder type
- 锥柄形式 Taper size

·SBT50-PHC 液压刀柄

SBT50-PHC HYDRAULIC TOOL HOLDER

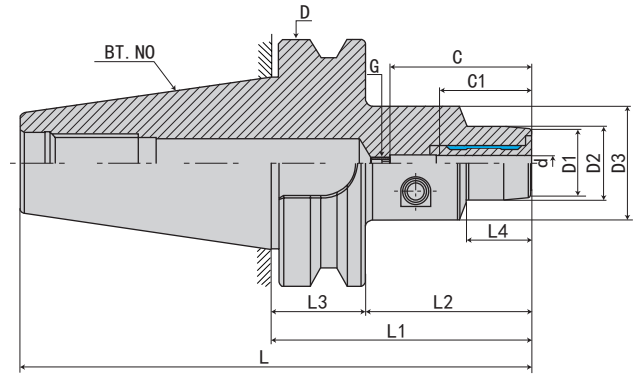

型号 Model	L	L1	L2	L3	L4	D	D1	D2	D3	d	最大插入深度 C Max. insertion depth	最少插入深度 C1 Min insertion depth	G	重量 KGS
SBT50-PHC05- 90	191.8	90	52	38	32	100	22	25	49.5	5	*	26	*	4.2
-120	221.8	120	82	38	44	100	22	25	49.5	5	*	26	*	4.5
-PHC06- 90	191.8	90	52	38	32	100	23	26	49.5	6	37	27	M5*0.8P	4.2
-120	221.8	120	82	38	44	100	23	26	49.5	6	37	27	M5*0.8P	4.5
-PHC08- 90	191.8	90	52	38	32	100	25	28	49.5	8	37	27	M6*1.0P	4.2
-120	221.8	120	82	38	44	100	25	28	49.5	8	37	27	M6*1.0P	4.5
-PHC10- 90	191.8	90	52	38	32	100	27	30	49.5	10	41	31	M8*1.0P	4.2
-120	221.8	120	82	38	44	100	27	30	49.5	10	41	31	M8*1.0P	4.5
-PHC12- 90	191.8	90	52	38	32	100	29	32	49.5	12	46	36	M10*1.0P	4.3
-120	221.8	120	82	38	44	100	29	32	49.5	12	46	36	M10*1.0P	4.5
-PHC14- 90	191.8	90	52	38	32	100	31	34	49.5	14	46	36	M10*1.0P	4.3
-120	221.8	120	82	38	44	100	31	34	49.5	14	46	36	M10*1.0P	4.6
-PHC16- 90	191.8	90	52	38	32	100	35	38	49.5	16	75	39	M12*1.0P	4.3
-120	221.8	120	82	38	48	100	35	38	49.5	16	75	39	M12*1.0P	4.6
-PHC18- 90	191.8	90	52	38	32	100	37	40	49.5	18	75	39	M12*1.0P	4.4
-120	221.8	120	82	38	48	100	37	40	49.5	18	75	39	M12*1.0P	4.6
-PHC20- 90	191.8	90	52	38	32	100	39	42	49.5	20	75	41	M16*1.0P	4.4
-120	221.8	120	82	38	48	100	39	42	49.5	20	75	41	M16*1.0P	4.7
-PHC25-120	221.8	120	82	38	48	100	53	57	63	25	80	47	M16*1.0P	4.9
-PHC32-120	221.8	120	82	38	48	100	58	62	70	32	90	51	M16*1.0P	5.2
-PHC40-120	221.8	120	82	38		100				40	90	61	M16*1.0P	6
-PHC42-120	221.8	120	82	38		100				42	90	61	M16*1.0P	6
-PHC50-120	221.8	120	82	38		100				50	90	61	M16*1.0P	7

规格说明:

SBT50 - PHC - 05 - 90

- L1 长度 Length (L1)
- 刀杆直径 Diameter
- 功能代号 Holder type
- 锥柄形式 Taper size

·SBT30-SPHC 液压刀柄

SBT30-SPHC HYDRAULIC TOOL HOLDER

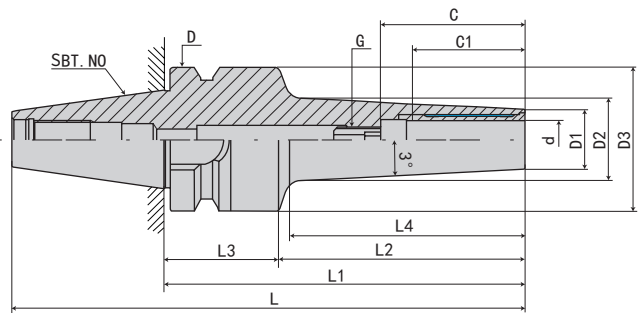

型号 Model	L	L1	L2	L3	L4	D	D1	D2	D3	d	最大插入深度 C Max.insertiondepth	最少插入深度 C1 Mininsertiondepth	G	重量 KGS
SBT30-SPHC03- 85	133.4	85	63	22	42	46	11		45	3	*	18	*	1.1
-SPHC04- 85	133.4	85	63	22	42	46	11		45	4	*	24	*	1.1
-SPHC05- 85	133.4	85	63	22	42	46	12		45	5	*	26	*	1.4
-SPHC06-115	163.4	115	93	22	74	46	13		45	6	37	27	M5*0.8P	1.4
-SPHC08-115	163.4	115	93	22	74	46	15		45	8	37	27	M6*1.0P	1.4
-SPHC10-115	163.4	115	93	22	74	46	17		45	10	41	31	M8*1.0P	1.4
-SPHC12-115	163.4	115	93	22	75	46	19		45	12	46	36	M10*1.0P	1.4

规格说明:

SBT30 - SPHC - 03 - 85

- L1 长度 Length (L1)
- 刀杆直径 Diameter
- 功能代号 Holder type
- 锥柄形式 Taper size

·SBT40-SPHC 液压刀柄

SBT40-SPHC HYDRAULIC TOOL HOLDER

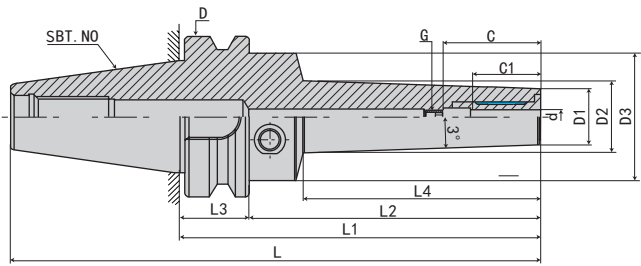

型号 Model	L	L1	L2	L3	L4	D	D1	D2	D3	d	最大插入深度 C Max. insertion depth	最少插入深度 C1 Min insertion depth	G	重量 KGS
SBT40-SPHC03- 90	155.4	90	63	27	42	63	11		46	3	*	18	*	1.1
-120	185.4	120	93	27	72	63	11		46	3	*	18	*	1.3
-SPHC04- 90	155.4	90	63	27	42	63	11		46	4	*	24	*	1.1
-120	185.4	120	93	27	72	63	11		46	4	*	24	*	1.3
-SPHC05- 90	155.4	90	63	27	42	63	12		46	5	*	26	*	1.4
-120	185.4	120	93	27	72	63	12		46	5	*	26	*	1.3
-SPHC06-120	185.4	120	93	27	74	63	13		46	6	37	27	M5*0.8P	1.4
-150	215.4	150	123	27	104	63	13		46	6	37	27	M5*0.8P	1.5
-200	265.4	200	173	27	154	63	13		46	6	37	27	M5*0.8P	1.7
-SPHC08-120	185.4	120	93	27	74	63	15		46	8	37	27	M6*1.0P	1.4
-150	215.4	150	123	27	104	63	15		46	8	37	27	M6*1.0P	1.5
-200	265.4	200	173	27	154	63	15		46	8	37	27	M6*1.0P	1.7
-SPHC10-120	185.4	120	93	27	74	63	17		46	10	41	31	M8*1.0P	1.4
-150	215.4	150	123	27	104	63	17		46	10	41	31	M8*1.0P	1.5
-200	265.4	200	173	27	154	63	17		46	10	41	31	M8*1.0P	1.7
-SPHC12-120	185.4	120	93	27	75	63	19		46	12	46	36	M10*1.0P	1.4
-150	215.4	150	123	27	105	63	19		46	12	46	36	M10*1.0P	1.5
-200	265.4	200	173	27	154	63	19		46	12	46	36	M10*1.0P	1.7
-SPHC14-120	185.4	120	93	27	75	63	21		46	14	46	36	M10*1.0P	1.4
-150	215.4	150	123	27	105	63	21		46	14	46	36	M10*1.0P	1.5
-200	265.4	200	173	27	154	63	21		46	14	46	36	M10*1.0P	1.7
-SPHC16-120	185.4	120	93	27	75	63	23		50	16	49	39	M12*1.0P	1.5
-150	215.4	150	123	27	105	63	23		50	16	49	39	M12*1.0P	1.6
-SPHC16-200	265.4	200	173	27	154	63	23		50	16	49	39	M12*1.0P	1.8
-SPHC18-120	185.4	120	93	27	75	63	25		50	18	49	39	M12*1.0P	1.5
-150	215.4	150	123	27	105	63	25		50	18	49	39	M12*1.0P	1.6
-200	265.4	200	173	27	154	63	25		50	18	49	39	M12*1.0P	1.8
-SPHC20-120	185.4	120	93	27	75	63	27		50	20	51	41	M16*1.0P	1.6
-150	215.4	150	123	27	105	63	27		50	20	51	41	M16*1.0P	1.7
-200	265.4	200	173	27	154	63	27		50	20	51	41	M16*1.0P	1.9

规格说明:

SBT40 - SPHC - 03 - 90

- L1 长度 Length (L1)
- 刀杆直径 Diameter
- 功能代号 Holder type
- 锥柄形式 Taper size

 D
 SBT SHANK SYSTEMS
 SBT 刀柄系列

·SBT50-SPHC 液压刀柄

SBT50-SPHC HYDRAULIC TOOL HOLDER

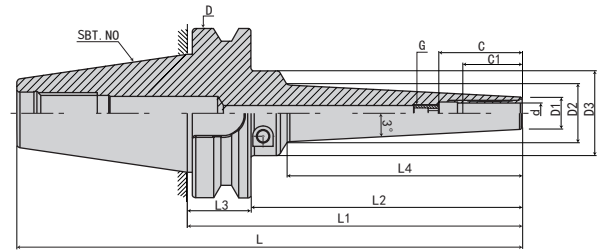

型号 Model	L	L1	L2	L3	L4	D	D1	D2	D3	d	最大插入深度 C Max. insertion depth	最少插入深度 C1 Min insertion depth	G	重量 KGS
SBT50-SPHC05-150	251.8	150	112	38	80	100	12		50	5	*	26	*	4.2
-200	301.8	200	162	38	130	100	12		50	5	*	26	*	4.4
-250	351.8	250	212	38	180	100	12		50	5	*	26	*	4.6
-300	401.8	300	262	38	230	100	12		50	5	*	26	*	4.8
-SPHC06-150	251.8	150	112	38	80	100	13		50	6	37	27	M5*0.8P	4.2
-200	301.8	200	162	38	130	100	13		50	6	37	27	M5*0.8P	4.4
-250	351.8	250	212	38	180	100	13		50	6	37	27	M5*0.8P	4.6
-300	401.8	300	262	38	230	100	13		50	6	37	27	M5*0.8P	4.8
-SPHC08-150	251.8	150	112	38	80	100	15		50	8	37	27	M6*1.0P	4.2
-200	301.8	200	162	38	130	100	15		50	8	37	27	M6*1.0P	4.4
-250	351.8	250	212	38	180	100	15		50	8	37	27	M6*1.0P	4.6
-300	401.8	300	262	38	230	100	15		50	8	37	27	M6*1.0P	4.8
-SPHC10-150	251.8	150	112	38	80	100	17		50	10	41	31	M8*1.0P	4.3
-200	301.8	200	162	38	130	100	17		50	10	41	31	M8*1.0P	4.5
-250	351.8	250	212	38	180	100	17		50	10	41	31	M8*1.0P	4.7
-300	401.8	300	262	38	230	100	17		50	10	41	31	M8*1.0P	4.9
-SPHC12-150	251.8	150	112	38	80	100	19		50	12	46	36	M10*1.0P	4.3
-200	301.8	200	162	38	130	100	19		50	12	46	36	M10*1.0P	4.5
-250	351.8	250	212	38	180	100	19		50	12	46	36	M10*1.0P	4.7
-300	401.8	300	262	38	230	100	19		50	12	46	36	M10*1.0P	4.9
-SPHC14-150	251.8	150	112	38	80	100	21		50	14	46	36	M10*1.0P	4.4
-200	301.8	200	162	38	130	100	21		50	14	46	36	M10*1.0P	4.6
-250	351.8	250	212	38	180	100	21		50	14	46	36	M10*1.0P	4.8
-300	401.8	300	262	38	230	100	21		50	14	46	36	M10*1.0P	5
-SPHC16-150	251.8	150	112	38	80	100	23		50	16	75	39	M12*1.0P	4.4
-200	301.8	200	162	38	130	100	23		50	16	75	39	M12*1.0P	4.6
-250	351.8	250	212	38	180	100	23		50	16	75	39	M12*1.0P	4.8
-300	401.8	300	262	38	230	100	23		50	16	75	39	M12*1.0P	5
-SPHC18-150	251.8	150	112	38	80	100	25		50	18	75	39	M12*1.0P	4.5
-200	301.8	200	162	38	130	100	25		50	18	75	39	M12*1.0P	4.7
-250	351.8	250	212	38	180	100	25		50	18	75	39	M12*1.0P	4.9
-300	401.8	300	262	38	230	100	25		50	18	75	39	M12*1.0P	5.1
-SPHC20-150	251.8	150	112	38	80	100	27		50	20	75	41	M16*1.0P	4.6
-200	301.8	200	162	38	130	100	27		50	20	75	41	M16*1.0P	4.8
-250	351.8	250	212	38	180	100	27		50	20	75	41	M16*1.0P	5
-300	401.8	300	262	38	230	100	27		50	20	75	41	M16*1.0P	5.2

规格说明:

SBT50 - SPHC - 05 - 150

- L1 长度 Length (L1)
- 刀杆直径 Diameter
- 功能代号 Holder type
- 锥柄形式 Taper size

·SBT-SLK 热缩基础柄

SBT-SLK SEMI-FINISHED SHRINK FIT CHUCK

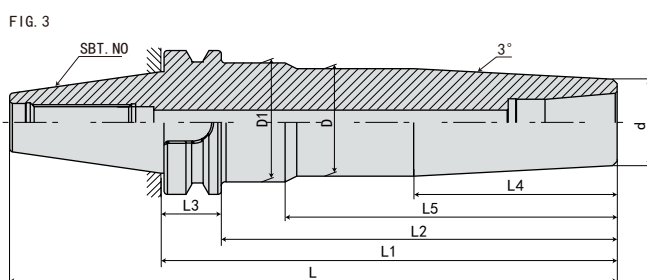
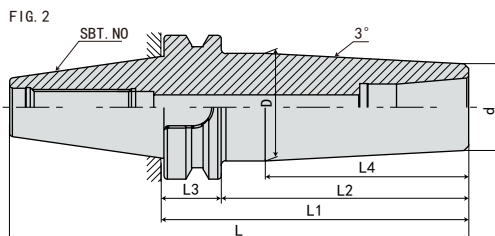
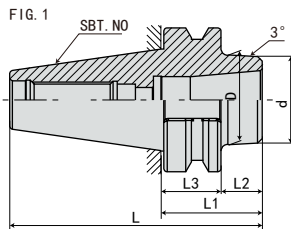

规格 Model	L	L1	L2	L3	L4	L5	D	D1	d	FIG	重量 KGS
SBT30-SLK12- 45	93.4	45	24	22	-	-	40	-	38	1	
SBT40-SLK12- 45	110.4	45	19	27	-	-	40	-	38	1	1.15
- 75	140.4	75	49	27	-	-	42.4	-	38	1	1.45
-135	200.4	135	109	27	89	-	47	-	38	2	2.2
-165	230.4	165	139	27	89	-	47	-	38	2	2.65
-200	265.4	200	174	27	89	145	47	52	38	3	3.25
-225	290.4	225	199	27	89	145	47	52	38	3	

规格说明:

SBT30 - SLK - 12 - 45

- L1 长度 Length (L1)
- 刀杆直径 Diameter
- 功能代号 Holder type
- 锥柄形式 Taper size

·SBT50-SLK 热缩基础柄

SBT50-SLK SEMI-FINISHED SHRINK FIT CHUCK

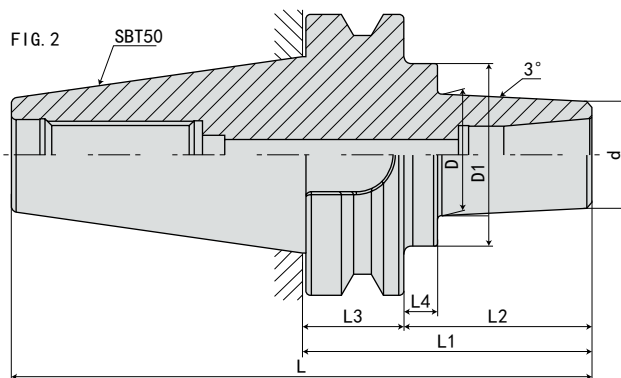
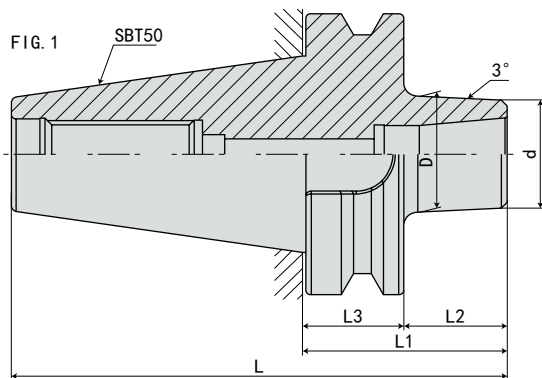
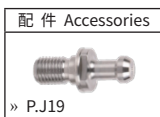

规格 Model	L	L1	L2	L3	L4	D	D1	d	FIG	重量 KGS
SBT50-SLK12- 75	176.8	75	38.5	38	-	41	-	38	1	
-105	206.8	105	68.5	38	12	43	65	38	2	
-135	236.8	135	98.5	38	12	46.5	65	38	2	
-165	266.8	165	128.5	38	12	50	65	38	2	
-225	326.8	225	188.5	38	12	56	65	38	2	
-265	366.8	265	228.5	38	12	60	65	38	2	
-315	416.8	315	278.5	38	12	65.5	65.5	38	2	

规格说明:

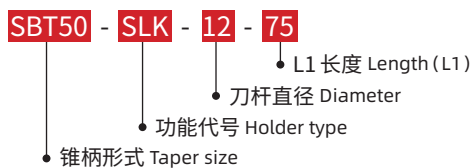

· SBT-C 型高精度强力刀柄

SBT-C FORCE MILLING CHUCK

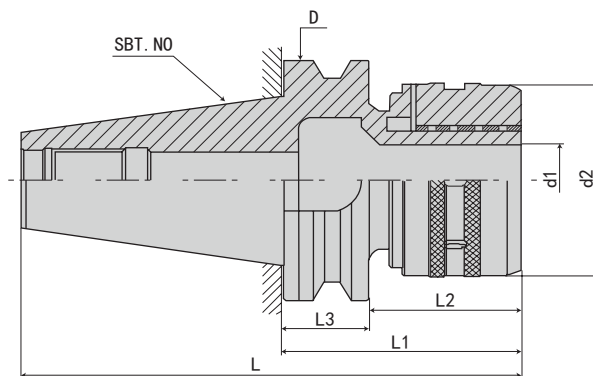

规格 Model	L	L1	L2	L3	D	d1	d2	夹持范围 Range	重量 KGS
SBT30-C20-80	128.4	80	59	22	46	20	58	3 4 5 6 8 10 12 14 16 20	
-C25-100	148.4	100	79	22	46	25	63	3 4 5 6 8 10 12 14 16 18 20 25	
-C32-105	153.4	105	84	22	46	32	73	3 4 5 6 8 10 12 14 16 18 20 22 24 25 32	
SBT40-C20-100	165.4	100	74	27	63	20	58	3 4 5 6 8 10 12 14 16 20	
-C25-100	165.4	100	74	27	63	25	63	3 4 5 6 8 10 12 14 16 18 20 25	
-135	200.4	135	109	27	63	25	63	3 4 5 6 8 10 12 14 16 18 20 25	
-C32-105	170.4	105	79	27	63	32	73	3 4 5 6 8 10 12 14 16 18 20 22 24 25 32	
-135	200.4	135	109	27	63	32	73	3 4 5 6 8 10 12 14 16 18 20 22 24 25 32	
-165	230.4	165	139	27	63	32	73	3 4 5 6 8 10 12 14 16 18 20 22 24 25 32	
-200	265.4	200	174	27	63	32	73	3 4 5 6 8 10 12 14 16 18 20 22 24 25 32	
SBT50-C25-110	211.8	110	73.5	38	100	25	63	3 4 5 6 8 10 12 14 16 18 20 25	
-135	236.8	135	98.5	38	100	25	63	3 4 5 6 8 10 12 14 16 18 20 25	
-165	266.8	165	128.5	38	100	25	63	3 4 5 6 8 10 12 14 16 18 20 25	
-C32-110	211.8	110	73.5	38	100	32	73	3 4 5 6 8 10 12 14 16 18 20 22 24 25 32	
-135	236.8	135	98.5	38	100	32	73	3 4 5 6 8 10 12 14 16 18 20 22 24 25 32	
-165	266.8	165	128.5	38	100	32	73	3 4 5 6 8 10 12 14 16 18 20 22 24 25 32	
-200	301.8	200	163.5	38	100	32	73	3 4 5 6 8 10 12 14 16 18 20 22 24 25 32	
-250	351.8	250	213.5	38	100	32	73	3 4 5 6 8 10 12 14 16 18 20 22 24 25 32	
-300	401.8	300	263.5	38	100	32	73	3 4 5 6 8 10 12 14 16 18 20 22 24 25 32	
-C42-135	236.8	135	98.5	38	100	42	88	3 4 5 6 8 10 12 14 16 18 20 22 24 25 28 30 32 34 36 42	
-165	266.8	165	128.5	38	100	42	88	3 4 5 6 8 10 12 14 16 18 20 22 24 25 28 30 32 34 36 42	
-200	301.8	200	163.5	38	100	42	88	3 4 5 6 8 10 12 14 16 18 20 22 24 25 28 30 32 34 36 42	

特点:

高速、高精度、高寿命直柄刀具系列

- ◎ 材质: 20CrMnTi/15CrMn
- ◎ 硬度: HRC58-60, 渗碳深度 > 0.8mm
- ◎ 锥柄公差等级: ≤ AT3
- ◎ 刀柄内孔分割了六槽, 以防止刀具转动, 增大夹持力
- ◎ 采用特殊材料制作滚针轴承保持架, 延长使用寿命, 增强夹紧力
- ◎ 具有夹持力大, 定点精度高, 特别适用于强力切削
- ◎ 可提供两种外观: 光饰或涂层处理
- ◎ 内孔多次研磨, 可达 Ra0.4, 起到镜面效果
- ◎ 外圆及端面多次研磨, 可达 Ra0.4, 起到镜面效果
- ◎ 表面“环保”特殊涂层处理, 提高表面硬度、耐磨性, 提高清洁度, 精度更稳定, 表面更光滑, 防锈、防腐蚀效果更好, 手感更舒适, 外观更美观
- ◎ 扳手、拉钉、筒夹须另行购买

规格说明:

- SBT30 - C - 20 - 80**
- 锥柄形式 Taper size
 - 筒夹种类 Collect type C
 - 筒夹型号 Collect model
 - L1 长度 Length (L1)

Features:

High speed, high accuracy, high durability C-STRAIGHT TOOL SERIES

- ◎ Material: 20CrMnTi/15CrMn;
- ◎ Hardness: HRC58-60, Carbon depth > 0.8
- ◎ Tolerance class: ≤ AT3
- ◎ Inner hole of the shank divide into 6 troughs to prevent the insert remove, increase the grasp force
- ◎ Ball bearing cage is made of special material, improve the endurance, enhance the grasp force
- ◎ Grasp force strong, centering accuracy high, suit to heavy cutting
- ◎ Two kinds looks provide: polishing or chemical nickel-plating processing;
- ◎ Inner hole grinding for many times, so as to reach Ra0.4, has a mirror effect;
- ◎ End and the cylindrical are grinding for many times, can reach Ra0.4, has a mirror effect;
- ◎ Surface "environmental protection", special coating surface treatment, improve the hardness and endurance of the surface, cleanliness better, accuracy stable, surface more smooth, antirust, feel comfortable, appearance nice.
- ◎ The spanner、pull stud chuck must purchase alone.

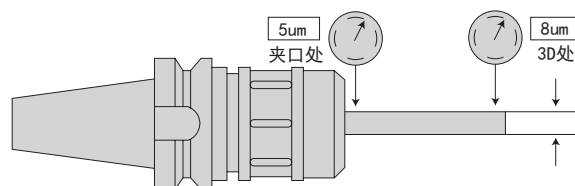

·SBT30-ER 弹性筒夹刀柄

SBT30-ER COLLET CHUCK

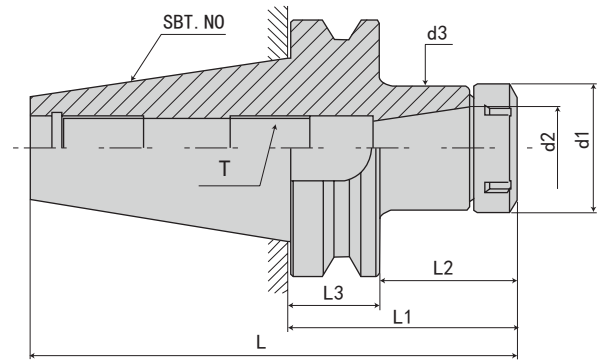

规格 Model	L	L1	L2	L3	d1	d2	d3	T	夹持范围 Range	重量 KGS
SBT30-ER11- 70	118.4	70	49	22	16	11	16	M6*1.0P	1-7mm	0.53
-100	148.4	100	79	22	16	11	16	M6*1.0P	1-7mm	0.53
-ER16- 70	118.4	70	49	22	28	16	28	M10*1.5P	1-10mm	0.61
-100	148.4	100	79	22	28	16	28	M10*1.5P	1-10mm	0.7
-ER20- 70	118.4	70	49	22	34	20	34	M12*1.75P	1-13mm	0.67
-100	148.4	100	79	22	34	20	34	M12*1.75P	1-13mm	0.8
-ER25- 70	118.4	70	49	22	42	25	42	M16*2.0P	1-16mm	0.7
-100	148.4	100	79	22	42	25	42	M16*2.0P	1-16mm	1
-ER32- 70	118.4	70	49	22	50	32	50	M16*2.0P	1-20mm	0.78
-100	148.4	100	79	22	50	32	50	M16*2.0P	1-20mm	1

规格说明:

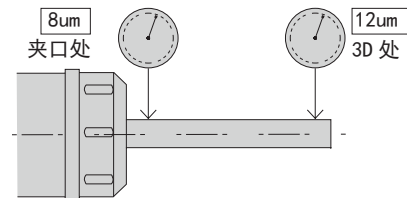

·SBT40-ER 弹性筒夹刀柄

SBT40-ER COLLET CHUCK

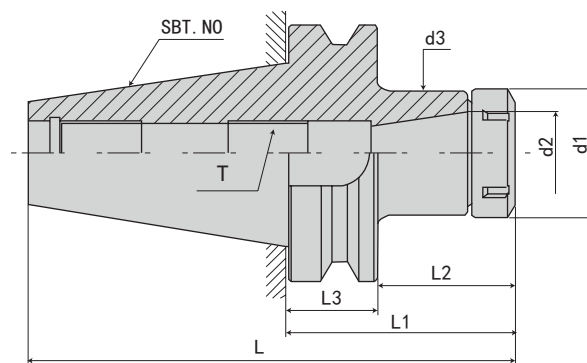

规格 Model	L	L1	L2	L3	d1	d2	d3	T	夹持范围 Range	重量 KGS
SBT40-ER11- 75	140.4	75	49	27	16	11	16	M6*1.0P	1-7mm	
-100	165.4	100	74	27	16	11	16	M6*1.0P	1-7mm	
-ER16- 75	140.4	75	49	27	28	16	28	M10*1.5P	1-10mm	1.3
-100	165.4	100	74	27	28	16	28	M10*1.5P	1-10mm	1.3
-120	185.4	120	94	27	28	16	28	M10*1.5P	1-10mm	1.42
-150	215.4	150	124	27	28	16	28	M10*1.5P	1-10mm	1.6
-ER20- 75	140.4	75	49	27	34	20	34	M12*1.75P	1-13mm	1.2
-100	165.4	100	74	27	34	20	34	M12*1.75P	1-13mm	1.4
-120	185.4	120	94	27	34	20	34	M12*1.75P	1-13mm	1.52
-150	215.4	150	124	27	34	20	34	M12*1.75P	1-13mm	1.7
-ER25- 75	140.4	75	49	27	42	25	42	M16*2.0P	1-16mm	1.3
-100	165.4	100	74	27	42	25	42	M16*2.0P	1-16mm	1.6
-120	185.4	120	94	27	42	25	42	M16*2.0P	1-16mm	1.78
-150	215.4	150	124	27	42	25	42	M16*2.0P	1-16mm	2.05
-ER32- 75	140.4	75	49	27	50	32	50	M16*2.0P	1-20mm	1.47
-100	165.4	100	74	27	50	32	50	M16*2.0P	1-20mm	1.7
-120	185.4	120	94	27	50	32	50	M16*2.0P	1-20mm	1.98
-150	215.4	150	124	27	50	32	50	M16*2.0P	1-20mm	2.4
-200	265.4	200	174	27	50	32	50	M16*2.0P	1-20mm	3.15
-ER40- 80	145.4	80	54	27	63	40	63	M20*2.0P	2-26mm	1.5
-100	165.4	100	74	27	63	40	63	M20*2.0P	2-26mm	2.1
-120	185.4	120	94	27	63	40	63	M20*2.0P	2-26mm	2.54
-150	215.4	150	124	27	63	40	63	M20*2.0P	2-26mm	3.2

规格说明:

SBT40 - ER - 11 - 75

- L1 长度 Length (L1)
- 筒夹型号 Collect model
- 筒夹种类 Collect type ER
- 锥柄形式 Taper size

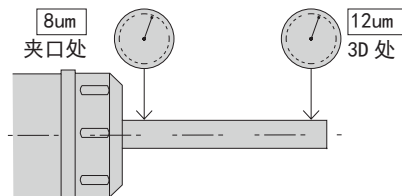

·SBT50-ER 弹性筒夹刀柄

SBT50-ER COLLET CHUCK

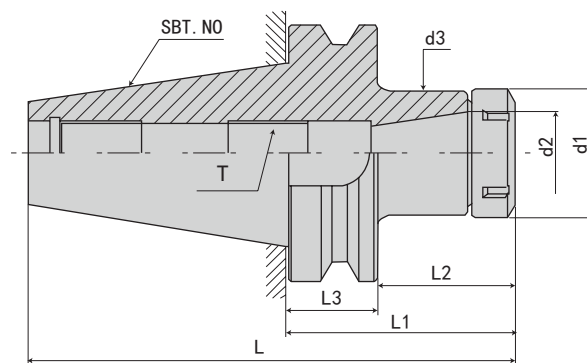

规格 Model	L	L1	L2	L3	d1	d2	d3	T	夹持范围 Range	重量 KGS
SBT50-ER16-100	201.8	100	63.5	38	28	16	28	M10*1.5P	1-10mm	3.9
-135	236.8	135	98.5	38	28	16	28	M10*1.5P	1-10mm	4.04
-165	266.8	165	128.5	38	28	16	28	M10*1.5P	1-10mm	4.16
-200	301.8	200	163.5	38	28	16	28	M10*1.5P	1-10mm	4.3
-ER20-100	201.8	100	63.5	38	34	20	34	M12*1.75P	1-13mm	4
-135	236.8	135	98.5	38	34	20	34	M12*1.75P	1-13mm	4.21
-165	263.8	165	128.5	38	34	20	34	M12*1.75P	1-13mm	4.39
-200	301.8	200	163.5	38	34	20	34	M12*1.75P	1-13mm	4.6
-ER25-100	201.8	100	63.5	38	42	25	42	M16*2.0P	1-16mm	4.1
-135	236.8	135	98.5	38	42	25	42	M16*2.0P	1-16mm	4.45
-165	266.8	165	128.5	38	42	25	42	M16*2.0P	1-16mm	4.75
-200	301.8	200	163.5	38	42	25	42	M16*2.0P	1-16mm	5.1
-250	351.8	250	213.5	38	42	25	42	M16*2.0P	1-16mm	5.8
-300	401.8	300	263.5	38	42	25	42	M16*2.0P	1-16mm	6.2
-ER32-100	201.8	100	63.5	38	50	32	50	M16*2.0P	1-20mm	4.2
-135	236.8	135	98.5	38	50	32	50	M16*2.0P	1-20mm	4.725
-165	266.8	165	128.5	38	50	32	50	M16*2.0P	1-20mm	5.175
-200	301.8	200	163.5	38	50	32	50	M16*2.0P	1-20mm	5.7
-250	351.8	250	213.5	38	50	32	50	M16*2.0P	1-20mm	6.3
-300	401.8	300	263.5	38	50	32	50	M16*2.0P	1-20mm	7.2
-ER40-100	201.8	100	63.5	38	63	40	63	M20*2.0P	2-26mm	4.5
-135	236.8	135	98.5	38	63	40	63	M20*2.0P	2-26mm	5.27
-165	266.8	165	128.5	38	63	40	63	M20*2.0P	2-26mm	5.93
-200	301.8	200	163.5	38	63	40	63	M20*2.0P	2-26mm	6.7
-250	351.3	250	213.5	38	63	40	63	M20*2.0P	2-26mm	7.8
-300	401.8	300	263.5	38	63	40	63	M20*2.0P	2-26mm	9
-ER50-100	201.8	100	63.5	38	78	50	78	M24*2.0P	5-34mm	3.9
-150	251.8	150	113.5	38	78	50	78	M24*2.0P	5-34mm	6.2

规格说明:

SBT50 - ER - 16 - 100

- L1 长度 Length (L1)
- 筒夹型号 Collect model
- 筒夹种类 Collect type ER
- 锥柄形式 Taper size

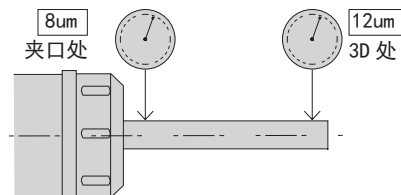

·SBT30-FMH 端面出水铣刀柄

SBT30-FMH FACE MILL HOLDER-COOLANT TYPE



FIG. 1

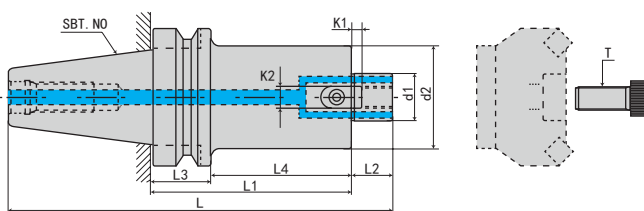
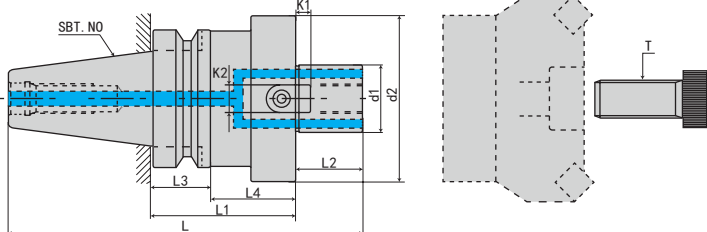
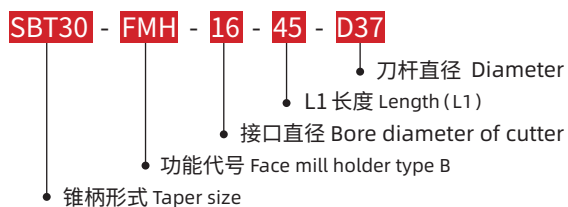

FIG. 2



规格 Model	L	L1	L2	L3	L4	d1	d2	K1	K2	T	FIG	重量 KGS
SBT30- FMH16-45-D37	110.4	45	17	22	24	16	37	3.2	8	M8*1.25P	1	
-60-D37	125.4	60	17	22	39	16	37	3.2	8	M8*1.25P	1	0.5
- FMH22-45-D47	111.4	45	18	22	24	22	47	4.8	10	M10*1.5P	2	0.75
-60-D47	126.4	60	18	22	39	22	47	4.8	10	M10*1.5P	2	1.5
- FMH27-45-D60	113.4	45	20	22	24	27	60	5.8	12	M12*1.75P	2	1.45
-60-D60	128.4	60	20	22	39	27	60	5.8	12	M12*1.75P	2	1.45
- FMH32-45-D68	115.4	45	22	22	24	32	68	6.8	14	M16*2.0P	2	1.5
-60-D68	130.4	60	22	22	39	32	68	6.8	14	M16*2.0P	2	1.5
- FMH25.4-45-D60	113.4	45	20	22	24	25.4	60	4.52	9.52	M12*1.75P	2	1.1
-60-D60	128.4	60	20	22	39	25.4	60	4.52	9.52	M12*1.75P	2	1.3
-FMH31.75-45-D68	115.4	45	22	22	24	31.75	68	6.7	12.7	M16*2.0P	2	1.35
-60-D68	130.4	60	22	22	39	31.75	68	6.7	12.7	M16*2.0P	2	1.5

规格说明:



·SBT40-FMH 端面出水铣刀柄

SBT40-FMH FACE MILL HOLDER-COOLANT TYPE



FIG. 1

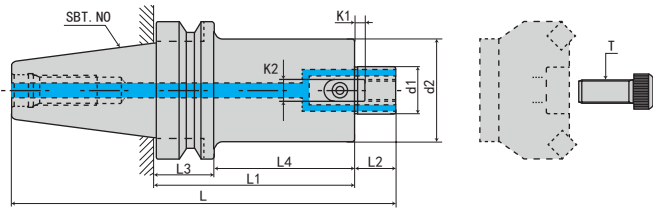
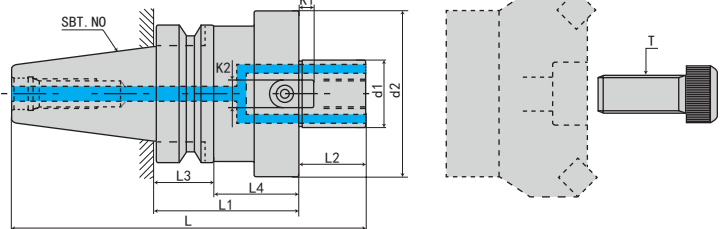
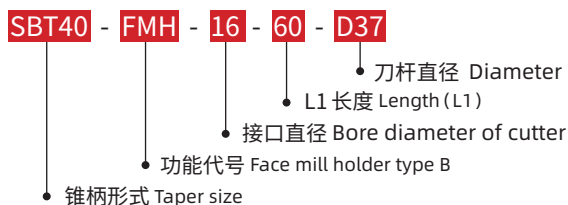

FIG. 2



规格 Model	L	L1	L2	L3	L4	d1	d2	K1	K2	T	FIG	重量 KGS
SBT40- FMH16- 60-D37	142.4	60	17	27	34	16	37	3.2	8	M8*1.25P	1	1.3
-100-D37	182.4	100	17	27	74	16	37	3.2	8	M8*1.25P	1	1.4
- FMH22- 45-D47	128.4	45	18	27	19	22	47	4.8	10	M10*1.5P	1	1.29
- 60-D47	143.4	60	18	27	34	22	47	4.8	10	M10*1.5P	1	1.5
-100-D47	183.4	100	18	27	74	22	47	4.8	10	M10*1.5P	1	2.05
-150-D47	233.4	150	18	27	124	22	47	4.8	10	M10*1.5P	1	2.75
-200-D47	283.4	200	18	27	174	22	47	4.8	10	M10*1.5P	1	3.6
-250-D47	333.4	250	18	27	224	22	47	4.8	10	M10*1.5P	1	4.25
- FMH27- 45-D60	130.4	45	20	27	19	27	60	5.8	12	M12*1.75P	1	2.23
- 60-D60	145.4	60	20	27	34	27	60	5.8	12	M12*1.75P	1	2.35
-100-D60	185.4	100	20	27	74	27	60	5.8	12	M12*1.75P	1	3.1
-150-D60	235.4	150	20	27	124	27	60	5.8	12	M12*1.75P	1	3.9
-200-D60	285.4	200	20	27	174	27	60	5.8	12	M12*1.75P	1	4.8
- FMH32- 45-D68	132.4	45	22	27	19	32	68	6.8	14	M16*2.0P	2	1.78
- 60-D68	147.4	60	22	27	34	32	68	6.8	14	M16*2.0P	2	1.9
-100-D68	187.4	100	22	27	74	32	68	6.8	14	M16*2.0P	2	2.8
-150-D68	237.4	150	22	27	124	32	68	6.8	14	M16*2.0P	2	3.6
- FMH40- 45-D78	135.4	45	25	27	19	40	78	8.3	16	M16*2.0P	2	2.605
- 60-D78	150.4	60	25	27	34	40	78	8.3	16	M16*2.0P	2	2.8
-100-D78	190.4	100	25	27	74	40	78	8.3	16	M16*2.0P	2	3.6
-150-D78	240.4	150	25	27	124	40	78	8.3	16	M16*2.0P	2	4.9
- FMH25.4- 45-D60	130.4	45	20	27	19	25.4	60	4.52	9.52	M12*1.75P	1	1.395
- 60-D60	145.4	60	20	27	34	25.4	60	4.52	9.52	M12*1.75P	1	1.5
-100-D60	185.4	100	20	27	74	25.4	60	4.52	9.52	M12*1.75P	1	2.05
-150-D60	235.4	150	20	27	124	25.4	60	4.52	9.52	M12*1.75P	1	2.75
-200-D60	285.4	200	20	27	174	25.4	60	4.52	9.52	M12*1.75P	1	3.6
-FMH31.75- 45-D68	132.4	45	22	27	19	31.75	68	6.7	12.7	M16*2.0P	2	1.87
- 60-D68	147.4	60	22	27	34	31.75	68	6.7	12.7	M16*2.0P	2	2.05
-100-D68	187.4	100	22	27	74	31.75	68	6.7	12.7	M16*2.0P	2	2.9
-150-D68	237.4	150	22	27	124	31.75	68	6.7	12.7	M16*2.0P	2	4.1
- FMH38.1- 45-D78	135.4	45	25	27	19	38.1	78	8.87	15.87	M16*2.0P	2	1.78
- 60-D78	150.4	60	25	27	34	38.1	78	8.87	15.87	M16*2.0P	2	2.1
-100-D78	190.4	100	25	27	74	38.1	78	8.87	15.87	M16*2.0P	2	2.95
-150-D78	240.4	150	25	27	124	38.1	78	8.87	15.87	M16*2.0P	2	4.02

规格说明:



·SBT50-FMH 端面出水铣刀柄

SBT50-FMH FACE MILL HOLDER-COOLANT TYPE

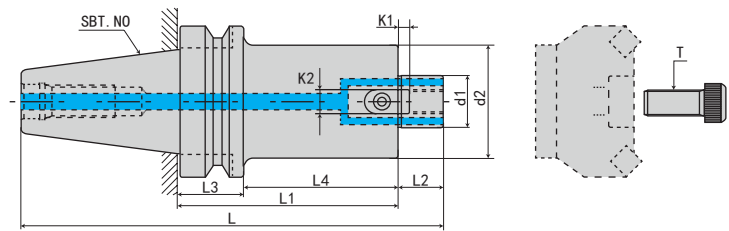

规格 Model	L	L1	L2	L3	L4	d1	d2	K1	K2	T	重量 KGS
SBT50-FMH16- 60-D37	178.8	60	17	38	23.5	16	37	3.2	8	M8*1.25P	4.0
-100-D37	218.8	100	17	38	63.5	16	37	3.2	8	M8*1.25P	4.2
-150-D37	268.3	150	17	38	113.5	16	37	3.2	8	M8*1.25P	4.5
-200-D37	318.8	200	17	38	163.5	16	37	3.2	8	M8*1.25P	4.8
-FMH22- 60-D47	179.8	60	18	38	23.5	22	47	4.8	10	M10*1.5P	4.6
-100-D47	219.8	100	18	38	63.5	22	47	4.8	10	M10*1.5P	4.55
-150-D47	269.8	150	18	38	113.5	22	47	4.8	10	M10*1.5P	5.25
-200-D47	319.8	200	18	38	163.5	22	47	4.8	10	M10*1.5P	6
-250-D47	369.8	250	18	38	213.5	22	47	4.8	10	M10*1.5P	7
-300-D47	419.8	300	18	38	263.5	22	47	4.8	10	M10*1.5P	7.7
-350-D47	469.8	350	18	38	313.5	22	47	4.8	10	M10*1.5P	8.4
-400-D47	519.8	400	18	38	363.5	22	47	4.8	10	M10*1.5P	9.2
-450-D47	569.8	450	18	38	413.5	22	47	4.8	10	M10*1.5P	10
-500-D47	619.8	500	18	38	463.5	22	47	4.8	10	M10*1.5P	11.2
-FMH22- 60-D60	179.8	60	18	38	23.5	22	60	4.8	10	M10*1.5P	4.4
-100-D60	219.8	100	18	38	63.5	22	60	4.8	10	M10*1.5P	5.2
-150-D60	269.8	150	18	38	113.5	22	60	4.8	10	M10*1.5P	6.3
-200-D60	319.8	200	18	38	163.5	22	60	4.8	10	M10*1.5P	7.2
-250-D60	369.8	250	18	38	213.5	22	60	4.8	10	M10*1.5P	8.3
-300-D60	419.8	300	18	38	263.5	22	60	4.8	10	M10*1.5P	
-350-D60	469.8	350	18	38	313.5	22	60	4.8	10	M10*1.5P	
-400-D60	519.8	400	18	38	363.5	22	60	4.8	10	M10*1.5P	
-450-D60	569.8	450	18	38	413.5	22	60	4.8	10	M10*1.5P	
-500-D60	619.8	500	18	38	463.5	22	60	4.8	10	M10*1.5P	
-FMH27- 45-D60	166.8	45	20	38	8.5	27	60	5.8	12	M12*1.75P	
- 60-D60	181.8	60	20	38	23.5	27	60	5.8	12	M12*1.75P	4.5
-100-D60	221.8	100	20	38	63.5	27	60	5.8	12	M12*1.75P	5.3
-150-D60	271.8	150	20	38	113.5	27	60	5.8	12	M12*1.75P	6.2
-200-D60	321.8	200	20	38	163.5	27	60	5.8	12	M12*1.75P	7.2
-250-D60	371.8	250	20	38	213.5	27	60	5.8	12	M12*1.75P	8.4
-300-D60	421.8	300	20	38	263.5	27	60	5.8	12	M12*1.75P	
-350-D60	471.8	350	20	38	313.5	27	60	5.8	12	M12*1.75P	
-400-D60	521.8	400	20	38	363.5	27	60	5.8	12	M12*1.75P	
-450-D60	571.8	450	20	38	413.5	27	60	5.8	12	M12*1.75P	
-500-D60	621.8	500	20	38	463.5	27	60	5.8	12	M12*1.75P	

规格说明:

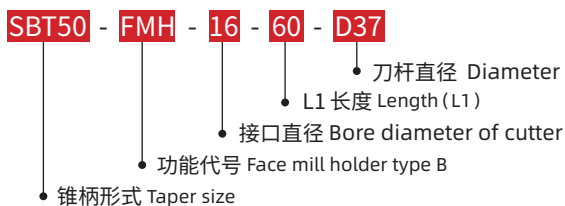
 D
 SBT SHANK SYSTEMS
 SBT 刀柄系列

·SBT50-FMH 端面出水铣刀柄

SBT50-FMH FACE MILL HOLDER-COOLANT TYPE

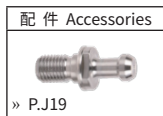

FIG. 1

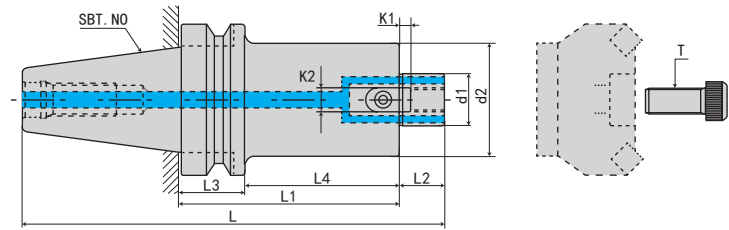
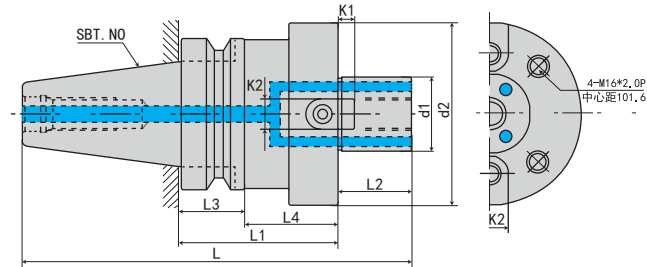
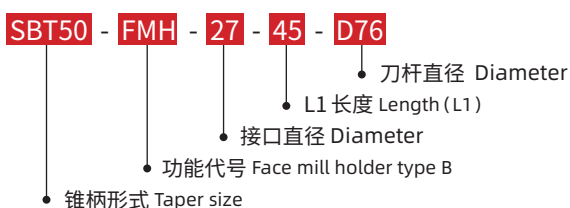

FIG. 2



规格 Model	L	L1	L2	L3	L4	d1	d2	K1	K2	T	FIG	重量 KGS
SBT50-FMH27- 45-D76	166.8	45	20	38	8.5	27	76	5.8	12	M12*1.75P	1	
- 60-D76	181.8	60	20	38	23.5	27	76	5.8	12	M12*1.75P	1	
-100-D76	221.8	100	20	38	63.5	27	76	5.8	12	M12*1.75P	1	
-150-D76	271.8	150	20	38	113.5	27	76	5.8	12	M12*1.75P	1	
-200-D76	321.8	200	20	38	163.5	27	76	5.8	12	M12*1.75P	1	
-250-D76	371.8	250	20	38	213.5	27	76	5.8	12	M12*1.75P	1	
-300-D76	421.8	300	20	38	263.5	27	76	5.8	12	M12*1.75P	1	
-350-D76	471.8	350	20	38	313.5	27	76	5.8	12	M12*1.75P	1	
-400-D76	521.8	400	20	38	363.5	27	76	5.8	12	M12*1.75P	1	
-450-D76	571.8	450	20	38	413.5	27	76	5.8	12	M12*1.75P	1	
-500-D76	621.8	500	20	38	463.5	27	76	5.8	12	M12*1.75P	1	
-FMH32- 45-D96	168.8	45	22	38	8.5	32	96	6.8	14	M16*2.0P	1	
- 60-D96	183.8	60	22	38	23.5	32	96	6.8	14	M16*2.0P	1	5.3
-100-D96	223.8	100	22	38	63.5	32	96	6.8	14	M16*2.0P	1	7.5
-150-D96	273.8	150	22	38	113.5	32	96	6.8	14	M16*2.0P	1	10.1
-200-D96	323.8	200	22	38	163.5	32	96	6.8	14	M16*2.0P	1	13
-250-D96	373.8	250	22	38	213.5	32	96	6.8	14	M16*2.0P	1	
-300-D96	423.8	300	22	38	263.5	32	96	6.8	14	M16*2.0P	1	
-350-D96	473.8	350	22	38	313.5	32	96	6.8	14	M16*2.0P	1	
-FMH40- 45-D100	171.8	45	25	38	8.5	40	100	8.3	16	M16*2.0P	1	
- 60-D100	186.8	60	25	38	23.5	40	100	8.3	16	M16*2.0P	1	5.7
-100-D100	226.8	100	25	38	63.5	40	100	8.3	16	M16*2.0P	1	8.2
-150-D100	276.8	150	25	38	113.5	40	100	8.3	16	M16*2.0P	1	10.8
-200-D100	326.8	200	25	38	163.5	40	100	8.3	16	M16*2.0P	1	13.9
-250-D100	376.8	250	25	38	213.5	40	100	8.3	16	M16*2.0P	1	
-300-D100	426.8	300	25	38	263.5	40	100	8.3	16	M16*2.0P	1	
-FMH60- 75-D128	201.8	75	25	38	38.5	60	128	12.5	25.4	M16*2.0P	2	
-100-D128	226.8	100	25	38	63.5	60	128	12.5	25.4	M16*2.0P	2	
-150-D128	276.8	150	25	38	113.5	60	128	12.5	25.4	M16*2.0P	2	

规格说明:



·SBT50-FMH 端面出水铣刀柄

SBT50-FMH FACE MILL HOLDER-COOLANT TYPE

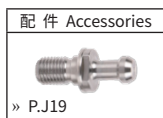

FIG. 1

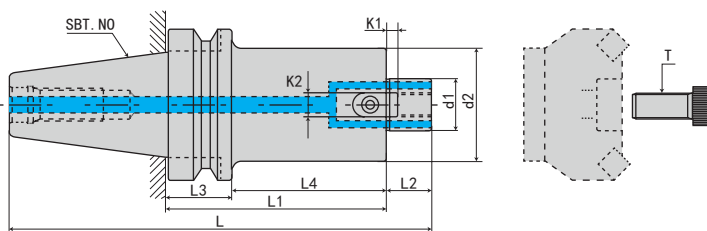
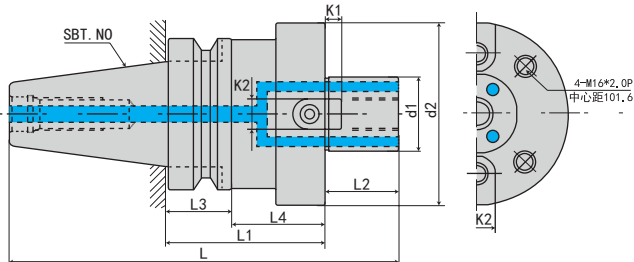

FIG. 2



规格 Model	L	L1	L2	L3	L4	d1	d2	K1	K2	T	FIG	重量 KGS
SBT50-FMH25.4-45-D60	166.8	45	20	38	8.5	25.4	60	4.52	9.52	M12*1.75P	1	
- 60-D60	181.8	60	20	38	23.5	25.4	60	4.52	9.52	M12*1.75P	1	4.5
-100-D60	221.8	100	20	38	63.5	25.4	60	4.52	9.52	M12*1.75P	1	5.3
-150-D60	271.8	150	20	38	113.5	25.4	60	4.52	9.52	M12*1.75P	1	6.4
-200-D60	321.8	200	20	38	163.5	25.4	60	4.52	9.52	M12*1.75P	1	7.4
-250-D60	371.8	250	20	38	213.5	25.4	60	4.52	9.52	M12*1.75P	1	
-300-D60	421.8	300	20	38	263.5	25.4	60	4.52	9.52	M12*1.75P	1	
- 45-D76	166.8	45	20	38	8.5	25.4	76	4.52	9.52	M12*1.75P	1	
- 60-D76	181.8	60	20	38	23.5	25.4	76	4.52	9.52	M12*1.75P	1	
-100-D76	221.8	100	20	38	63.5	25.4	76	4.52	9.52	M12*1.75P	1	
-150-D76	271.8	150	20	38	113.5	25.4	76	4.52	9.52	M12*1.75P	1	
-200-D76	321.8	200	20	38	163.5	25.4	76	4.52	9.52	M12*1.75P	1	
-250-D76	371.8	250	20	38	213.5	25.4	76	4.52	9.52	M12*1.75P	1	
-300-D76	421.8	300	20	38	263.5	25.4	76	4.52	9.52	M12*1.75P	1	
-FMH31.75-45-D96	168.8	45	22	38	8.5	31.75	96	6.7	12.7	M16*2.0P	1	
- 60-D96	183.8	60	22	38	23.5	31.75	96	6.7	12.7	M16*2.0P	1	5.3
-100-D96	223.8	100	22	38	63.5	31.75	96	6.7	12.7	M16*2.0P	1	7.5
-150-D96	273.8	150	22	38	113.5	31.75	96	6.7	12.7	M16*2.0P	1	10.3
-200-D96	323.8	200	22	38	163.5	31.75	96	6.7	12.7	M16*2.0P	1	13
-250-D96	373.8	250	22	38	213.5	31.75	96	6.7	12.7	M16*2.0P	1	
-300-D96	423.8	300	22	38	263.5	31.75	96	6.7	12.7	M16*2.0P	1	
- FMH38.1-45-D100	171.8	45	25	38	8.5	38.1	100	8.87	15.87	M16*2.0P	1	
- 60-D100	186.8	60	25	38	23.5	38.1	100	8.87	15.87	M16*2.0P	1	5.6
-100-D100	226.8	100	25	38	63.5	38.1	100	8.87	15.87	M16*2.0P	1	8
-150-D100	276.8	150	25	38	113.5	38.1	100	8.87	15.87	M16*2.0P	1	
-200-D100	326.8	200	25	38	163.5	38.1	100	8.87	15.87	M16*2.0P	1	
-250-D100	376.8	250	25	38	213.5	38.1	100	8.87	15.87	M16*2.0P	1	
-300-D100	426.8	300	25	38	263.5	38.1	100	8.87	15.87	M16*2.0P	1	
-FMH47.625-75-D128	201.8	75	25	38	38.5	47.625	128	12.5	25.4	M16*2.0P	2	7.9
-100-D128	226.8	100	25	38	63.5	47.625	128	12.5	25.4	M16*2.0P	2	
-150-D128	276.8	150	25	38	113.5	47.625	128	12.5	25.4	M16*2.0P	2	

规格说明:

SBT50 - FMH - 25.4 - 45 - D60

- 刀杆直径 Diameter
- L1 长度 Length (L1)
- 接口直径 Diameter
- 功能代号 Face mill holder type B
- 锥柄形式 Taper size

·SBT30-SLN 侧固式刀柄

SBT30-SLN SIDE LOCK END MILL HOLDER

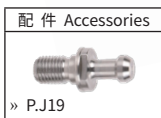
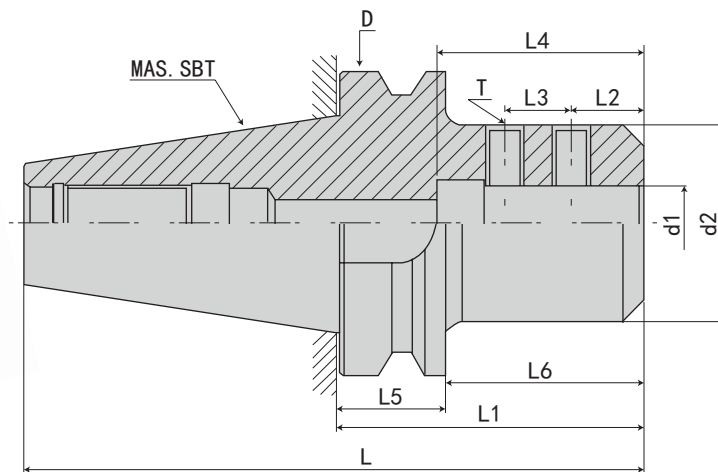

规格 Model	L	L1	L2	L3	L4	L5	L6	d1	d2	T	重量 KGS
SBT30-SLN16-75	123.4	75	14	14	48	22	54	16	48	M10*1.5P	1.03
-SLN20-75	123.4	75	14	14	50	22	54	20	48	M10*1.5P	0.98
-SLN25-80	128.4	80	15	20	56	22	59	25	48	M16*2.0P	0.97
-SLN32-85	133.4	85	15	20	60	22	59	32	63	M16*2.0P	1.38

规格说明:

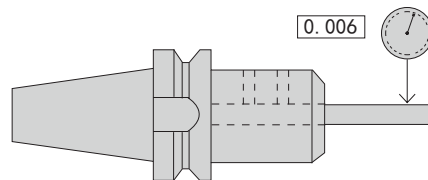
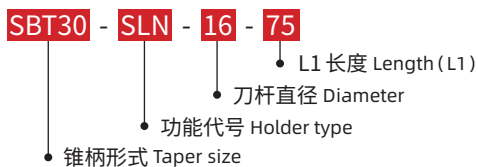

·SBT40-SLN 侧固式刀柄

SBT40-SLN SIDE LOCK END MILL HOLDER

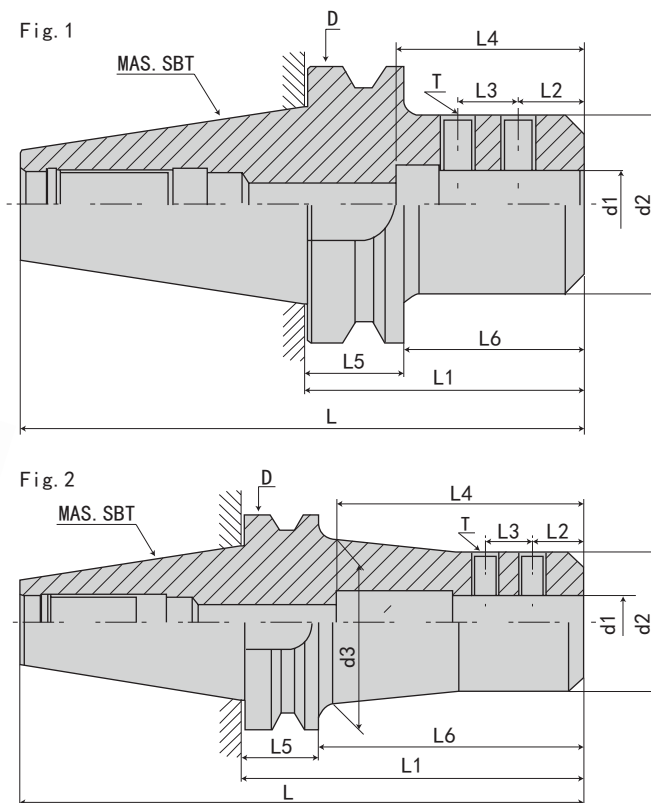

规格 Model	L	L1	L2	L3	L4	L5	L6	d1	d2	d3	FIG	T	重量 KGS
SBT40-SLN16-100	165.4	100	22	18	100	27	74	16	48	-	1	M10*1.5P	2
-150	215.4	150	22	18	100	27	124	16	40	45	2	M10*1.5P	2.2
-200	265.4	200	22	18	100	27	174	16	40	45	2	M10*1.5P	
-SLN20-100	165.4	100	25	20	110	27	74	20	52	-	1	M12*1.75P	2
-150	215.4	150	25	20	110	27	124	20	45	50	2	M12*1.75P	2.5
-200	265.4	200	25	20	110	27	174	20	45	50	2	M12*1.75P	
-SLN25-100	165.4	100	24	25	120	27	74	25	65	-	1	M12*1.75P	2.5
-150	215.4	150	24	25	120	27	124	25	50	55	2	M12*1.75P	2.6
-200	265.4	200	24	25	120	27	174	25	50	55	2	M12*1.75P	
-SLN32-100	165.4	100	24	28	120	27	74	32	65	-	1	M16*2.0P	2.4
-150	215.4	150	24	28	120	27	124	32	58	63	2	M16*2.0P	2.9
-200	265.4	200	24	28	120	27	174	32	58	63	2	M16*2.0P	
-SLN40-105	170.4	105	30	32	120	27	79	40	73	-	1	M16*2.0P	2.8
-150	215.4	150	30	32	120	27	124	40	73	-	1	M16*2.0P	3.8
-200	265.4	200	30	32	120	27	174	40	73	-	1	M16*2.0P	

规格说明:

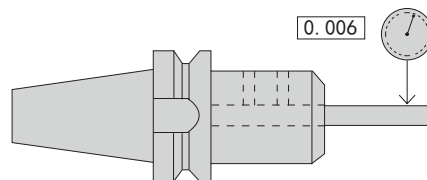

·SBT50-SLN 侧固式刀柄

SBT50-SLN SIDE LOCK END MILL HOLDER

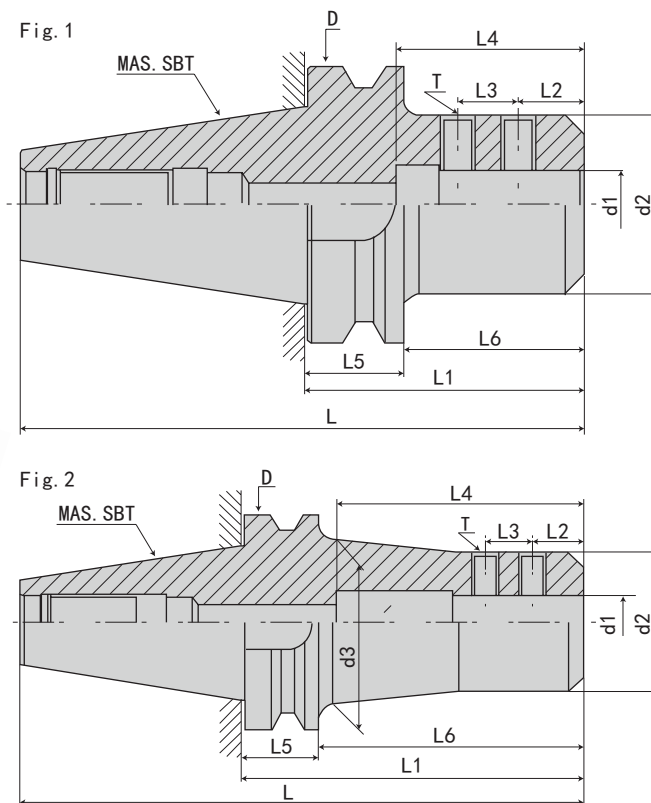
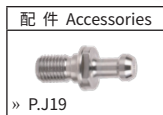

规格 Model	L	L1	L2	L3	L4	L5	L6	d1	d2	d3	FIG	T	重量 KGS
SBT50-SLN16-100	201.8	100	22	18	100	38	63.5	16	48	-	1	M10*1.5P	4.7
-135	236.8	135	22	18	100	38	98.5	16	48	-	1	M10*1.5P	
-165	266.8	165	22	18	100	38	128.5	16	40	45	2	M10*1.5P	
-200	301.8	200	22	18	100	38	163.5	16	40	45	2	M10*1.5P	
-250	351.8	250	22	18	100	38	213.5	16	40	45	2	M10*1.5P	
-SLN20-100	201.8	100	25	20	110	38	63.5	20	52	-	1	M12*1.75P	4.8
-135	236.8	135	25	20	110	38	98.5	20	52	-	1	M12*1.75P	
-165	266.8	165	25	20	110	38	128.5	20	45	50	2	M12*1.75P	
-200	301.8	200	25	20	110	38	163.5	20	45	50	2	M12*1.75P	
-250	351.8	250	25	20	110	38	213.5	20	45	50	2	M12*1.75P	
-SLN25-105L	206.8	105	24	25	120	38	68.5	25	65	-	1	M12*1.75P	5.4
-135L	236.8	135	24	25	120	38	98.5	25	65	-	1	M12*1.75P	
-165L	266.8	165	24	25	120	38	128.5	25	50	55	2	M12*1.75P	
-200	301.8	200	24	25	120	38	163.5	25	50	55	2	M12*1.75P	
-250	351.8	250	24	25	120	38	213.5	25	50	55	2	M12*1.75P	
-300	401.8	300	24	25	120	38	263.5	25	50	55	2	M12*1.75P	
-SLN32-105	206.8	105	24	28	120	38	68.5	32	72	-	1	M16*2.0P	5.5
-135	236.8	135	24	28	120	38	98.5	32	72	-	1	M16*2.0P	
-165	266.8	165	24	28	120	38	128.5	32	60	65	2	M16*2.0P	
-200	301.8	200	24	28	120	38	163.5	32	60	65	2	M16*2.0P	
-250	351.8	250	24	28	120	38	213.5	32	60	65	2	M16*2.0P	
-300	401.8	300	24	28	120	38	263.5	32	60	65	2	M16*2.0P	

规格说明:

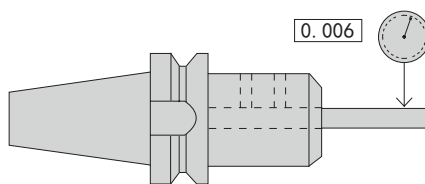

·SBT50-SLN 侧固式刀柄

SBT50-SLN SIDE LOCK END MILL HOLDER

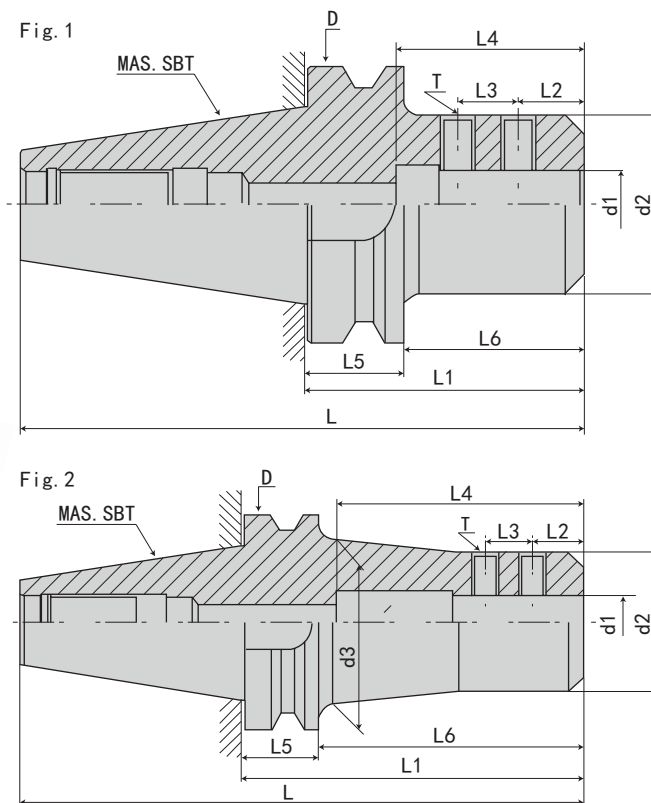

规格 Model	L	L1	L2	L3	L4	L5	L6	d1	d2	d3	FIG	T	重量 KGS
SBT50- SLN40-115	216.8	115	30	32	120	38	78.5	40	80	-	1	M20*2.5P	5.8
-135	236.8	135	30	32	120	38	98.5	40	80	-	1	M20*2.5P	
-165	266.8	165	30	32	120	38	128.5	40	70	75	2	M16*2.0P	
-200	301.8	200	30	32	120	38	163.5	40	70	75	2	M16*2.0P	
-250	351.8	250	30	32	120	38	213.5	40	70	75	2	M16*2.0P	
-300	401.8	300	30	32	120	38	263.5	40	70	75	2	M16*2.0P	
- SLN42-115	216.8	115	30	32	120	38	78.5	42	80	-	1	M20*2.5P	5.6
-135	236.8	135	30	32	120	38	98.5	42	80	-	1	M20*2.5P	
-165	266.8	165	30	32	120	38	128.5	42	70	75	2	M16*2.0P	
-200	301.8	200	30	32	120	38	163.5	42	70	75	2	M16*2.0P	
- SLN50-120	221.8	120	35	35	120	38	78.5	50	90	-	1	M20*2.5P	
-150	251.8	150	35	35	120	38	113.5	50	85	90	2	M20*2.5P	
-200	301.8	200	35	35	120	38	163.5	50	85	90	2	M20*2.5P	
-SLN50.8-120	221.8	120	35	35	120	38	78.5	50.8	90	-	1	M20*2.5P	
-150	251.8	150	35	35	120	38	113.5	50.8	85	90	2	M20*2.5P	
-200	301.8	200	35	35	120	38	163.5	50.8	85	90	2	M20*2.5P	

规格说明:

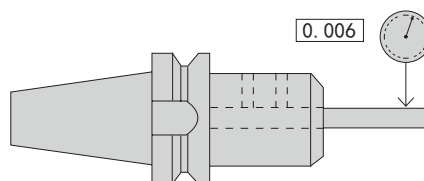
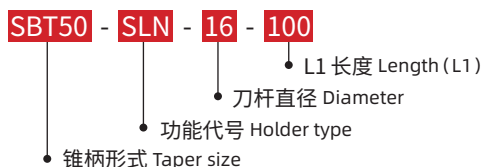

·SBT30-CK 镗头刀柄

SBT30-CK BORING HEAD SHANK

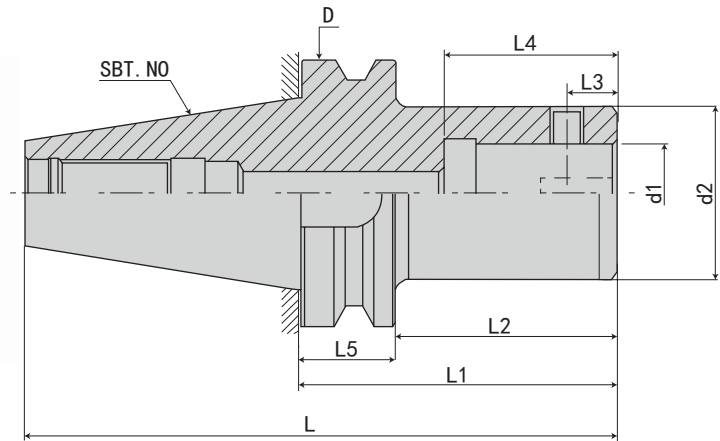

配件 Accessories



» P.J19

规格 Model	L	L1	L2	L3	L4	L5	d1	d2	D	T	重量 KGS
SBT30-CK1-105	153.4	105	84	5.05	30	22	11	19	46	M4*0.5P	0.51
-CK2- 75	123.4	75	54	6.62	31	22	14	24	46	M5*0.5P	0.44
-120	168.4	120	99	6.62	31	22	14	24	46	M5*0.5P	0.57
-CK3- 80	128.4	80	59	8	35	22	18	31	46	M6*0.75P	0.45
-120	168.4	120	99	8	35	22	18	31	46	M6*0.75P	0.67
-CK4- 85	133.4	85	64	10	39	22	22	39	46	M8*0.75P	0.46
-120	168.4	120	99	10	39	22	22	39	46	M8*0.75P	0.78
-CK5- 85	133.4	85	64	13	45	22	28	50	46	M10*1.0P	0.76
-120	168.4	120	99	13	45	22	28	50	46	M10*1.0P	0.80
-CK6- 85	133.4	85	64	16	55	22	36	63	46	M12*1.0P	0.85
-135	183.4	135	114	16	55	22	36	63	46	M12*1.0P	0.93

规格说明:

SBT30 - CK - 1 - 105

- L1 长度 Length (L1)
- 刀杆直径 Diameter
- 功能代号 Holder type
- 锥柄形式 Taper size

·SBT40-CK 镗头刀柄

SBT40-CK BORING HEAD SHANK

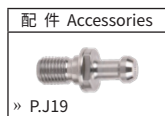
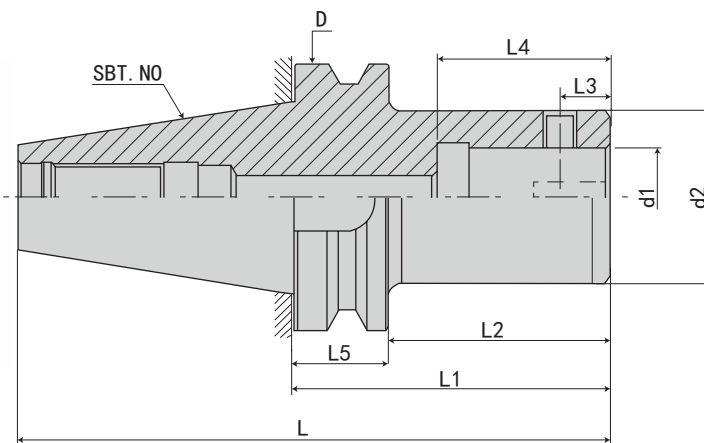

规格 Model	L	L1	L2	L3	L4	L5	d1	d2	D	T	重量 KGS
SBT40-CK1-105	170.4	105	79	5.05	30	27	11	19	63	M4*0.5P	
-CK2- 80	145.4	80	54	6.62	31	27	14	24	63	M5*0.5P	
-120	185.4	120	94	6.62	31	27	14	24	63	M5*0.5P	
-CK3- 85	150.4	85	59	8	35	27	18	31	63	M6*0.75P	
-135	200.4	135	109	8	35	27	18	31	63	M6*0.75P	
-165	230.4	165	139	8	35	27	18	31	63	M6*0.75P	
-CK4- 90	155.4	90	64	10	39	27	22	39	63	M8*0.75P	
-135	200.4	135	109	10	39	27	22	39	63	M8*0.75P	
-165	230.4	165	139	10	39	27	22	39	63	M8*0.75P	
-195	260.4	195	169	10	39	27	22	39	63	M8*0.75P	
-CK5- 65	105.4	65	39	13	45	27	28	50	63	M10*1.0P	
-105	170.4	105	79	13	45	27	28	50	63	M10*1.0P	
-135	200.4	135	109	13	45	27	28	50	63	M10*1.0P	
-165	230.4	165	139	13	45	27	28	50	63	M10*1.0P	
-195	260.4	195	169	13	45	27	28	50	63	M10*1.0P	
-CK6- 65	130.4	65	39	16	55	27	36	63	63	M12*1.0P	
-105	170.4	105	79	16	55	27	36	63	63	M12*1.0P	
-135	200.4	135	109	16	55	27	36	63	63	M12*1.0P	
-165	230.4	165	139	16	55	27	36	63	63	M12*1.0P	
-195	260.4	195	169	16	55	27	36	63	63	M12*1.0P	
-245	310.4	245	219	16	55	27	36	63	63	M12*1.0P	

规格说明:



·SBT50-CK 镗头刀柄

SBT50-CK BORING HEAD SHANK

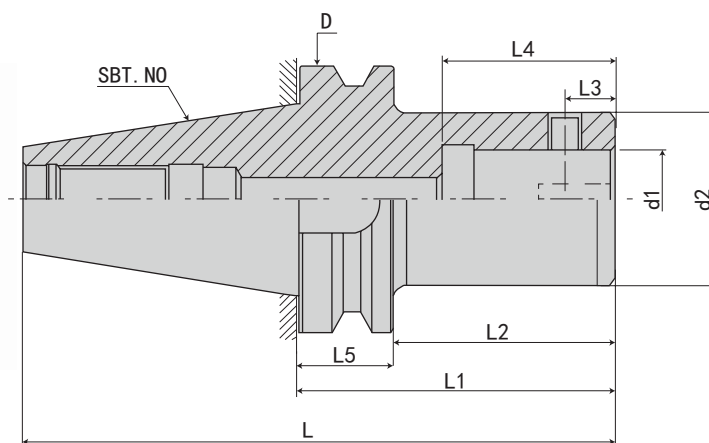

配件 Accessories



» P.J19

规格 Model	L	L1	L2	L3	L4	L5	d1	d2	D	T	重量 KGS
SBT50-CK1-135	236.8	135	98.5	5.05	30	38	11	19	100	M4*0.5P	4.3
-CK2- 90	191.8	90	53.5	6.62	31	38	14	24	100	M5*0.5P	
-115	216.8	115	78.5	6.62	31	38	14	24	100	M5*0.5P	4.1
-150	251.8	150	113.5	6.62	31	38	14	24	100	M5*0.5P	4.5
-CK3- 95	196.8	95	58.5	8	35	38	18	31	100	M6*0.75P	
-125	226.8	125	88.5	8	35	38	18	31	100	M6*0.75P	4.3
-165	266.8	165	128.5	8	35	38	18	31	100	M6*0.75P	4.7
-205	306.8	205	168.5	8	35	38	18	31	100	M6*0.75P	4.9
-CK4-105	206.8	105	68.5	10	39	38	22	39	100	M8*0.75P	
-165	266.8	165	128.5	10	39	38	22	39	100	M8*0.75P	5.1
-225	326.8	225	188.5	10	39	38	22	39	100	M8*0.75P	
-255	356.8	255	218.5	10	39	38	22	39	100	M8*0.75P	5.6
-300	401.8	300	263.5	10	39	38	22	39	100	M8*0.75P	
-CK5- 90	191.8	90	53.5	13	45	38	28	50	100	M10*1.0P	
-120	221.8	120	83.5	13	45	38	28	50	100	M10*1.0P	
-165	266.8	165	128.5	13	45	38	28	50	100	M10*1.0P	5.5
-205	306.8	205	168.5	13	45	38	28	50	100	M10*1.0P	5.8
-240	341.8	240	203.5	13	45	38	28	50	100	M10*1.0P	
-285	386.8	285	248.5	13	45	38	28	50	100	M10*1.0P	
-320	421.8	320	283.5	13	45	38	28	50	100	M10*1.0P	
-CK6- 95	196.8	95	58.5	16	55	38	36	63	100	M12*1.0P	4.9
-165	266.8	165	128.5	16	55	38	36	63	100	M12*1.0P	
-240	341.8	240	203.5	16	55	38	36	63	100	M12*1.0P	
-300	401.8	300	263.5	16	55	38	36	63	100	M12*1.0P	9.5
-360	461.8	360	323.5	16	55	38	36	63	100	M12*1.0P	10.5
-CK7-150	251.8	150	113.5	19.1	55	38	46	90	100	M20*1.5P	
-210	311.8	210	173.5	19.1	55	38	46	90	100	M20*1.5P	
-300	401.8	300	263.5	19.1	55	38	46	90	100	M20*1.5P	
-360	461.8	360	323.5	19.1	55	38	46	90	100	M20*1.5P	

规格说明:

SBT50 - CK - 1 - 135

- L1 长度 Length (L1)
- 接口锥度 Taper No. of cutter
- 功能代号 Holder type
- 锥柄形式 Taper size

·SBT30-MTA 带扁尾莫氏刀柄

SBT30-MTA TAPER ADAPTER(MORSE)

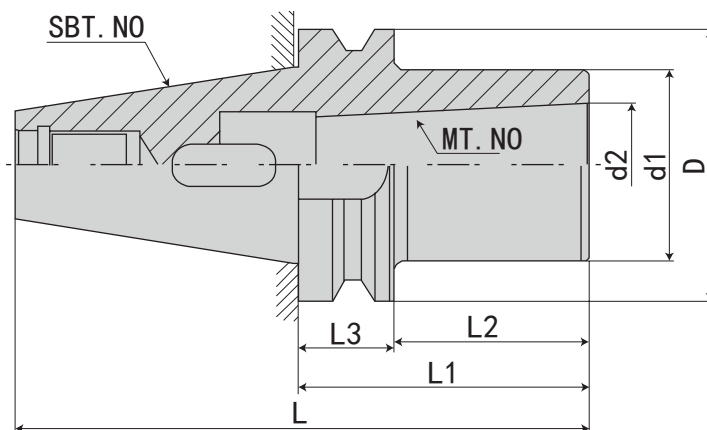
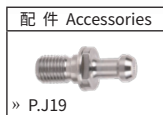

规格 Model	L	L1	L2	L3	D	d1	d2	夹持范围 Range	重量 KGS
SBT30-MTA1-60	108.4	60	39	22	46	25	12.065	Φ2-Φ14	
-MTA2-60	108.4	60	39	22	46	32	17.18	Φ14-Φ23	
-MTA3-80	128.4	80	59	22	46	40	23.825	Φ23-Φ32	

规格说明:

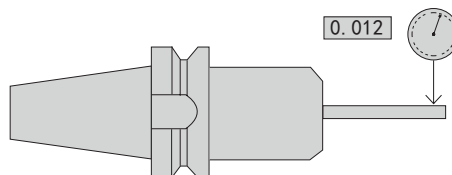

·SBT40-MTA 带扁尾莫氏刀柄

SBT40-MTA TAPER ADAPTER(MORSE)

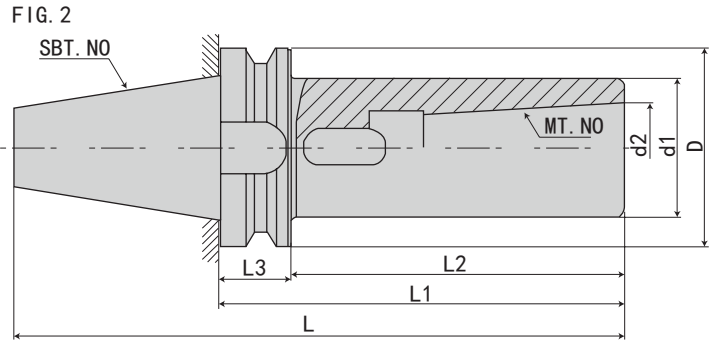
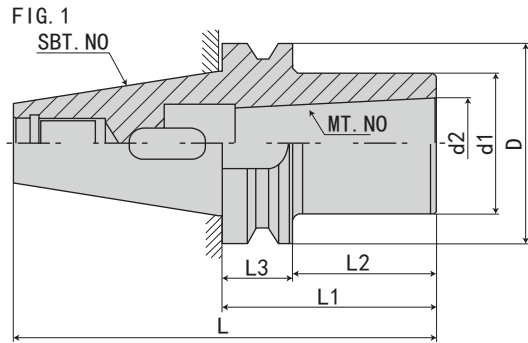

规格 Model	L	L1	L2	L3	D	d1	d2	FIG	夹持范围 Range	重量 KGS
SBT40-MTA1- 45	110.4	45	19	27	63	25	12.065	1	Φ2-Φ14	
-120	185.4	120	94	27	63	25	12.065	2	Φ2-Φ14	
-MTA2- 45	110.4	45	19	27	63	32	17.18	1	Φ14-Φ23	
-120	185.4	120	94	27	63	32	17.18	2	Φ14-Φ23	
-MTA3- 75	140.4	75	49	27	63	40	23.825	1	Φ23-Φ32	
-135	200.4	135	109	27	63	40	23.825	2	Φ23-Φ32	
-MTA4- 90	155.4	90	64	27	63	48	31.267	1	Φ32-Φ50	
-180	245.4	180	154	27	63	48	31.267	2	Φ32-Φ50	

规格说明:

- SBT40 - MTA - 1 - 45
- L1 长度 Length (L1)
 - 莫氏锥度号 Morse taper No.
 - 有扁尾莫氏锥孔 Morse taper holder type A
 - 锥柄形式 Diameter

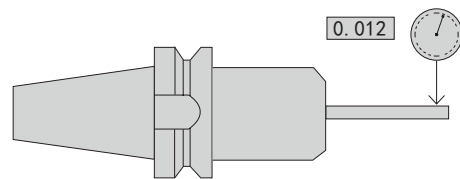

·SBT50-MTA 带扁尾莫氏刀柄

SBT50-MTA TAPER ADAPTER(MORSE)

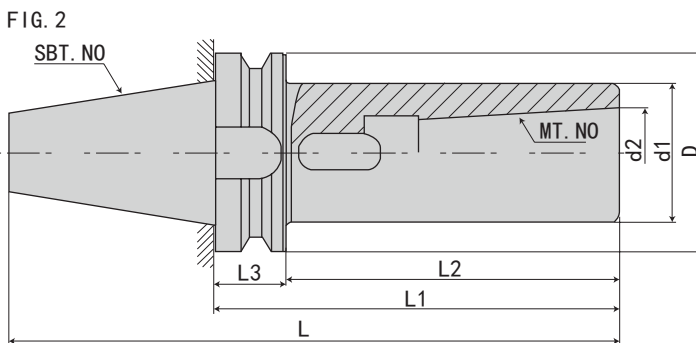
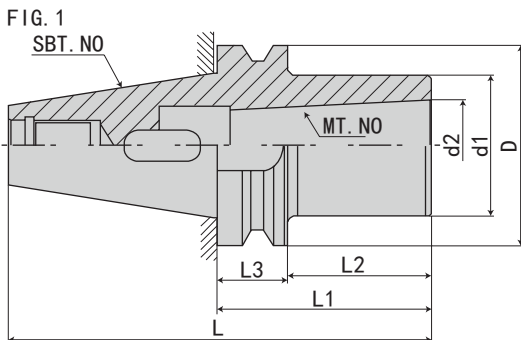
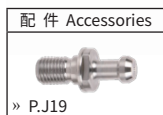

规格 Mode	L	L1	L2	L3	D	d1	d2	FIG	夹持范围 Range	重量 KGS
SBT50-MTA1- 45	146.8	45	8.5	38	100	25	12.065	1	Φ2-Φ14	
-120	221.8	120	83.5	38	100	25	12.065	2	Φ2-Φ14	4.3
-180	281.8	180	143.5	38	100	25	12.065	2	Φ2-Φ14	
-210	311.8	210	173.5	38	100	25	12.065	2	Φ2-Φ14	
-MTA2- 60	161.8	60	23.5	38	100	32	17.18	1	Φ14-Φ23	
-135	236.8	135	98.5	38	100	32	17.18	2	Φ14-Φ23	4.5
-180	281.8	180	143.5	38	100	32	17.18	2	Φ14-Φ23	
-210	311.8	210	173.5	38	100	32	17.18	2	Φ14-Φ23	
-250	351.8	250	213.5	38	100	32	17.18	2	Φ14-Φ23	
-MTA3- 75	176.8	75	38.5	38	100	40	23.825	1	Φ23-Φ32	4.1
-150	251.8	150	113.5	38	100	40	23.825	2	Φ23-Φ32	
-180	281.8	180	143.5	38	100	40	23.825	2	Φ23-Φ32	
-210	311.8	210	173.5	38	100	40	23.825	2	Φ23-Φ32	
-250	351.8	250	213.5	38	100	40	23.825	2	Φ23-Φ32	
-300	401.8	300	263.5	38	100	40	23.825	2	Φ23-Φ32	
-MTA4- 75	176.8	75	38.5	38	100	48	31.267	1	Φ32-Φ50	4
-180	281.8	180	143.5	38	100	48	31.267	2	Φ32-Φ50	
-210	311.8	210	173.5	38	100	48	31.267	2	Φ32-Φ50	
-250	351.8	250	213.5	38	100	48	31.267	2	Φ32-Φ50	
-300	401.8	300	263.5	38	100	48	31.267	2	Φ32-Φ50	
-MTA5-115	216.8	115	78.5	38	100	65	44.399	1	Φ50-Φ75	
-210	311.8	210	173.5	38	100	66	45.399	2	Φ50-Φ76	
-250	351.8	250	213.5	38	100	67	46.399	2	Φ50-Φ77	
-MTA6-200	301.8	200	163.5	38	100	85	63.348	1	Φ75-Φ100	
-280	381.8	280	243.5	38	100	85	63.348	2	Φ75-Φ100	

规格说明:

SBT50 - MTA - 1 - 45

- L1 长度 Length (L1)
- 莫氏锥度号 Morse taper No.
- 有扁尾莫氏锥孔 Morse taper holder type A
- 锥柄形式 Taper size

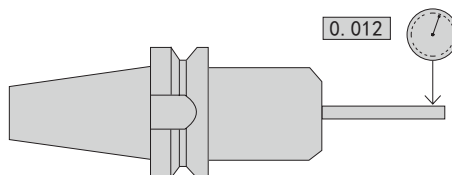

·SBT30-MTB 无扁尾莫氏刀柄

SBT30-MTB MORSE TAP HOLDER

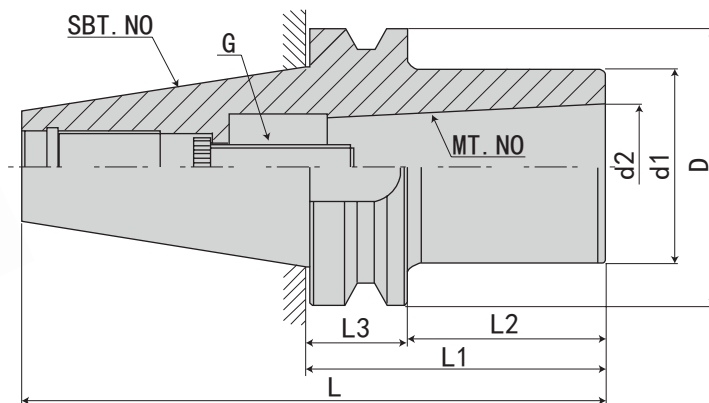
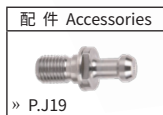

规格 Model	L	L1	L2	L3	D	d1	d2	夹持范围 Range	重量 KGS
SBT30-MTB1-60	108.4	60	39	22	46	25	12.065	Φ10-Φ14	
-MTB2-60	108.4	60	39	22	46	32	17.18	Φ16-Φ22	
-MTB3-80	128.4	80	59	22	46	40	23.825	Φ24-Φ32	

规格说明:

- SBT30 - MTB - 1 - 60
- L1 长度 Length (L1)
 - 莫氏锥度号 Morse taper No.
 - 无扁尾莫氏锥孔 Morse taper holder type B
 - 锥柄形式 Taper size

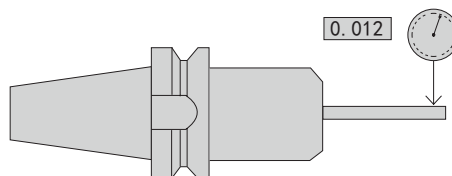

·SBT40-MTB 无扁尾莫氏刀柄

SBT40-MTB MORSE TAP HOLDER

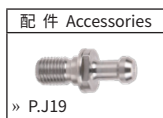
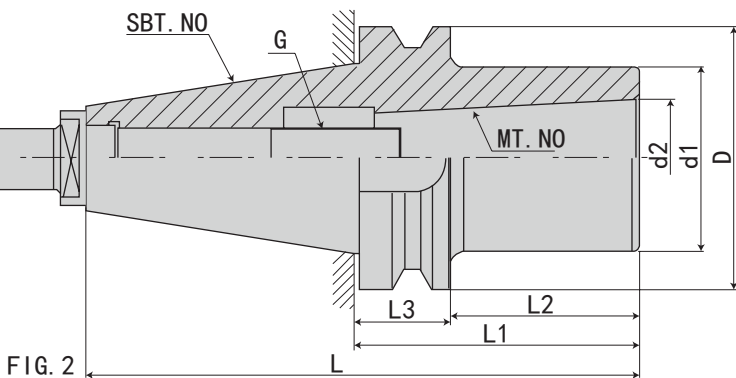
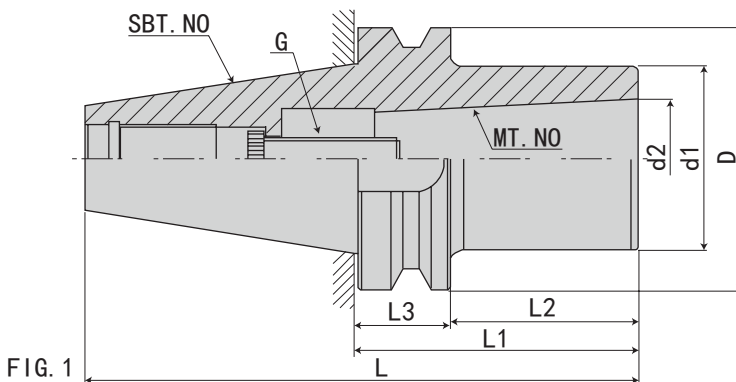

规格 Model	L	L1	L2	L3	D	d1	d2	FIG	夹持范围 Range	重量 KGS
SBT40-MTB1- 45	110.4	45	19	27	63	25	12.065	1	Φ10-Φ14	
-120	185.4	120	94	27	63	25	12.065	2	Φ10-Φ14	
-MTB2- 45	110.4	45	19	27	63	32	17.18	1	Φ16-Φ22	
-120	185.4	120	94	27	63	32	17.18	2	Φ16-Φ22	
-MTB3- 75	140.4	75	49	27	63	40	23.825	1	Φ24-Φ32	
-135	200.4	135	109	27	63	40	23.825	2	Φ24-Φ32	
-MTB4- 90	155.4	90	64	27	63	48	31.267	1	Φ32-Φ50	
-180	245.4	180	154	27	63	48	31.267	2	Φ32-Φ50	

规格说明:

- SBT40 - MTB - 1 - 45
- SBT40: 锥柄形式 Taper size
 - MTB: 无扁尾莫氏锥孔 Morse taper holder type B
 - 1: L1 长度 Length (L1)
 - 45: 莫氏锥度号 Morse taper No.

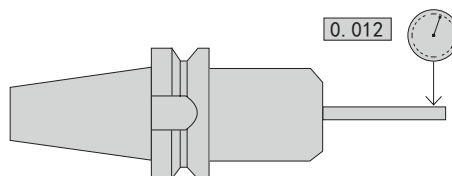

·SBT50-MTB 无扁尾莫氏刀柄

SBT50-MTB MORSE TAP HOLDER

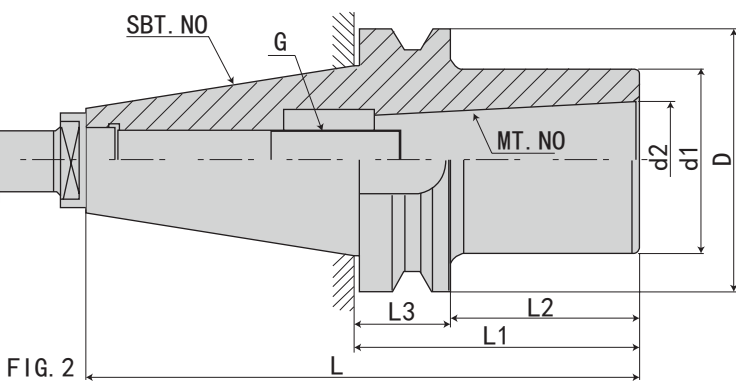
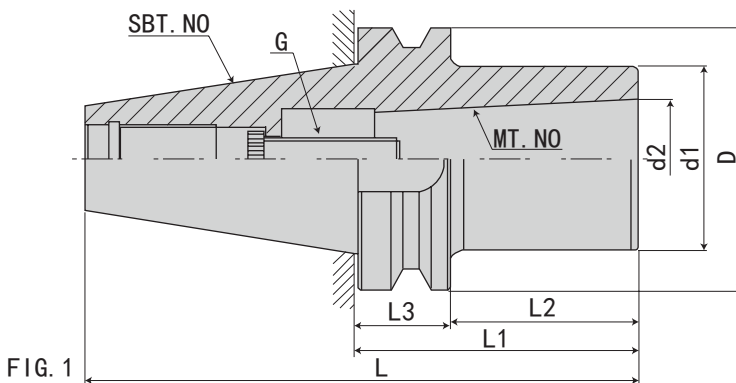

规格 Model	L	L1	L2	L3	D	d1	d2	FIG	夹持范围 Range	重量 KGS
SBT50-MTB1- 45	146.8	45	8.5	38	100	25	12.065	1	Φ10-Φ14	
-120	221.8	120	83.5	38	100	25	12.065	2	Φ10-Φ14	
-MTB2- 60	161.8	60	23.5	38	100	32	17.18	1	Φ16-Φ22	
-135	236.8	135	98.5	38	100	32	17.18	2	Φ16-Φ22	
-MTB3- 75	176.8	75	38.5	38	100	40	23.825	1	Φ24-Φ32	
-150	251.8	150	113.5	38	100	40	23.825	2	Φ24-Φ32	
-MTB4- 75	176.8	75	38.5	38	100	48	31.267	1	Φ32-Φ50	
-180	281.8	180	143.5	38	100	48	31.267	2	Φ32-Φ50	
-MTB5-115	216.8	115	78.5	38	100	65	44.399	1	Φ40-Φ75	
-210	311.8	210	173.5	38	100	66	45.399	2	Φ40-Φ75	

规格说明:

SBT50 - MTB - 1 - 45

- SBT50: 锥柄形式 Taper size
- MTB: 无扁尾莫氏锥孔, Morse taper holder type B
- 1: 莫氏锥度号 Morse taper No.
- 45: L1 长度 Length (L1)

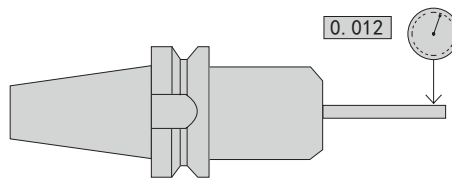

·SBT-APU 一体式钻夹头刀柄

SBT-APU DRILL CHUCK HOLDER

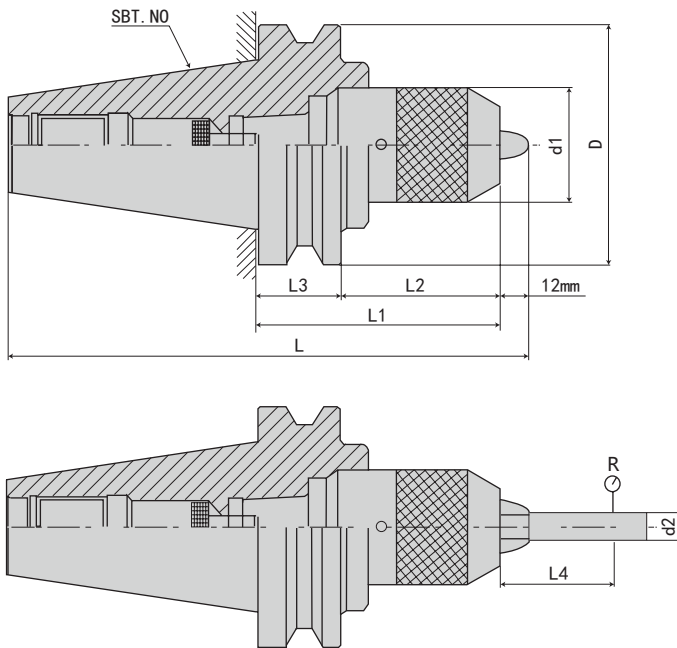

规格 Model	L	L1	L2	L3	d1	d2	D	R	夹持范围 Range	重量 KGS
SBT30-APU13-110	158.4	110	89	22	50	13	46	0.08	1-13mm	1.85
-APU16-115	163.4	115	94	22	57	16	46	0.08	1-16mm	2.18
SBT40-APU13-110	175.4	110	84	27	50	13	63	0.08	1-13mm	2
-APU16-110	175.4	110	84	27	57	16	63	0.08	1-16mm	2.3
SBT50-APU13-130	231.8	130	93.5	38	50	13	100	0.08	1-13mm	4.7
-180	281.8	180	143.5	38	50	13	100	0.08	1-13mm	5.85
-APU16-130	231.8	130	93.5	38	57	16	100	0.08	1-16mm	5.03
-180	281.8	180	143.5	38	57	16	100	0.08	1-16mm	5.85

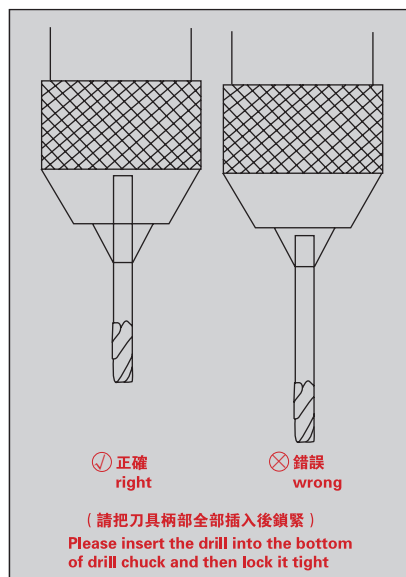

特点:

注:

- ◎ 一体式结构，减少了连接误差精度，内部用螺纹结构，就不会出现夹头脱落现象
- ◎ 用于钻头、铰刀等夹持，不可用于丝锥和铣刀夹持
- ◎ 一体刀柄缩短刀具长度，提高加工精度，增加使用寿命
- ◎ 有自锁功能，附带专用扳手，请勿用其它工具
- ◎ APU 偏摆精度为 0.06，如需更高精度要求请使用 ER 或 SK 系列
- ◎ 扳手、拉钉须另行购买

Features:

- ◎ The shank and keyless drill chuck are combined together so as to avoid the drill chuck slipping out for heavy-duty and high speed cutting and improve the precision.
- ◎ Not be used for gripping draw bolt and milling tools, instead of drill bit and reamer.
- ◎ APU drill chuck shorten the length while length the working life of tool.
- ◎ Each APU drill chuck attached 1pc APU wrench.
- ◎ The APU leaning precision is 0.06mm, like the need high accuracy request, please use ER or the SK serie.
- ◎ The spanner、pull stud must purchase alone.

规格说明:

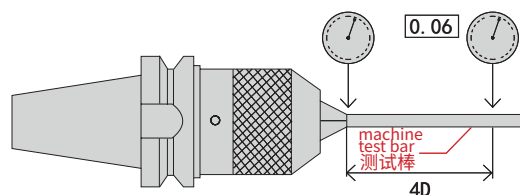

·SBT30-SLD 小径侧固刀柄

SBT30-SLD SMALL DIAMETER SIDE LOCK TOOL HOLDER

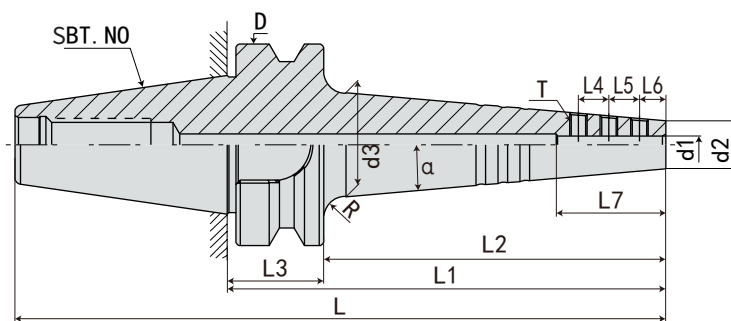

规格 Model	L	L1	L2	L3	L4	L5	L6	L7	D	d1	d2	d3	T	α	R	重量 KGS
SBT30-SLD3- 80-A5	128.4	80	58	22	6	6	6	18	46	3	9	18.5	M3.5*3*0.35P*T6	5°	5	
-100-A5	148.4	100	78	22	6	6	6	18	46	3	9	22	M3.5*3*0.35P*T6	5°	5	
-SLD4- 80-A5	128.4	80	58	22	7	7	6	20	46	4	11	20.5	M4*2.8*0.5P*H2	5°	5	
-100-A5	148.4	100	78	22	7	7	6	20	46	4	11	24	M4*2.8*0.5P*H2	5°	5	
-SLD6- 80-A5	128.4	80	58	22	8	8	6	22	46	6	13	22.5	M5*4*0.5P*H2.5	5°	5	
-100-A5	148.4	100	78	22	8	8	6	22	46	6	13	25.5	M5*4*0.5P*H2.5	5°	5	
-SLD8- 80-A5	128.4	80	58	22	10	10	7	27	46	8	15	24.5	M5*4*0.5P*H2.5	5°	5	
-100-A5	148.4	100	78	22	10	10	7	27	46	8	15	28	M5*4*0.5P*H2.5	5°	5	

规格说明:

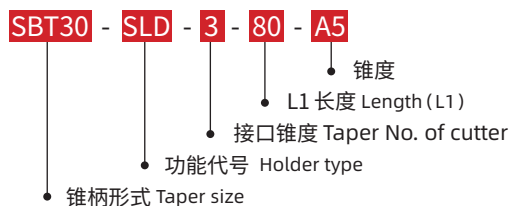

SLD 侧固式刀柄延长杆专用螺丝:

SLD side fixed extension rod special screw

规格 Model	使用孔径 D Using aperture
M3.5 × 3 × P0.35 × T6	D3
M4 × 2.8 × P0.5 × T8	D4
M4 × 4 × P0.5 × T8	D4
M5 × 3.5 × P0.5 × T10	D6
M5 × 5 × P0.5 × T10	D6 D8 D10
M6 × 4 × P0.75 × T15	D12
M6 × 6 × P0.75 × T15	D12
M8 × 5 × P0.75 × L4	D16 D20
M4 × 2.8 × P0.5 × H2	D4
M5 × 4 × P0.5 × H2.5	D6 D8 D10
M6 × 4 × P0.75 × H3	D12
M6 × 5 × P0.75 × H3	D12

备注：梅花扳手“T”，六角扳手“H”

六角扳手：更大的锁紧力（需注意控制尺寸）

梅花扳手：使用更方便

·SBT40-SLD 小径侧固刀柄

SBT40-SLD SMALL DIAMETER SIDE LOCK TOOL HOLDER

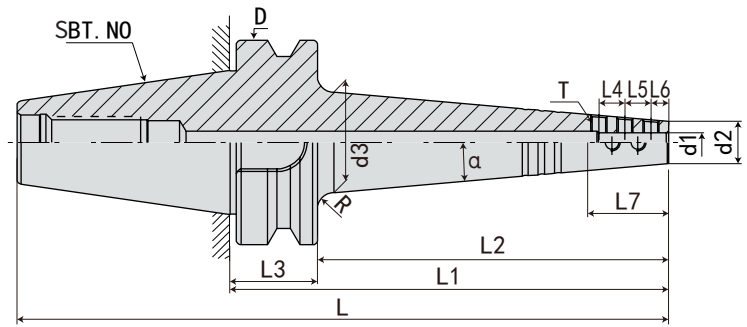
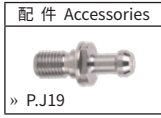

规格 Model	L	L1	L2	L3	L4	L5	L6	L7	D	d1	d2	d3	T	α	R	重量 KGS
SBT40- SLD3-135-A5	200.4	135	108	27	6	6	6	18	63	3	9	27	M3.5*3*0.35P*T6	5°	5	
- SLD4-135-A5	200.4	135	108	27	7	7	6	20	63	4	11	29	M4*2.8*0.5P*H2	5°	5	
- SLD6-135-A5	200.4	135	108	27	8	8	6	22	63	6	13	31	M5*4*0.5P*H2.5	5°	5	
-150-A5	215.4	150	123	27	8	8	6	22	63	6	13	33.5	M5*4*0.5P*H2.5	5°	5	
-200-A5	265.4	200	173	27	8	8	6	22	63	6	13	41.5	M5*4*0.5P*H2.5	5°	5	
- SLD8-135-A5	200.4	135	108	27	10	10	7	27	63	8	15	33	M5*4*0.5P*H2.5	5°	5	
-150-A5	215.4	150	123	27	10	10	7	27	63	8	15	35.5	M5*4*0.5P*H2.5	5°	5	
-200-A5	265.4	200	173	27	10	10	7	27	63	8	15	43.5	M5*4*0.5P*H2.5	5°	5	
-SLD10-135-A5	200.4	135	108	27	10	10	10	35	63	10	17	35	M5*4*0.5P*H2.5	5°	5	
-150-A5	215.4	150	123	27	10	10	10	35	63	10	17	37.5	M5*4*0.5P*H2.5	5°	5	
-200-A5	265.4	200	173	27	10	10	10	35	63	10	17	45.5	M5*4*0.5P*H2.5	5°	5	
-SLD12-135-A5	200.4	135	108	27	10	10	10	45	63	12	22	40	M6*5*0.75P*H3	5°	5	
-150-A5	215.4	150	123	27	10	10	10	45	63	12	22	42.5	M6*5*0.75P*H3	5°	5	
-200-A5	265.4	200	173	27	10	10	10	45	63	12	22	50.5	M6*5*0.75P*H3	5°	5	
- SLD6-150-A3	215.4	150	123	27	8	8	6	22	63	6	13	25.5	M5*4*0.5P*H2.5	3°	5	
-200-A3	265.4	200	173	27	8	8	6	22	63	6	13	30.5	M5*4*0.5P*H2.5	3°	5	
- SLD8-150-A3	215.4	150	123	27	10	10	7	27	63	8	15	27.5	M5*4*0.5P*H2.5	3°	5	
-200-A3	265.4	200	173	27	10	10	7	27	63	8	15	32.5	M5*4*0.5P*H2.5	3°	5	
-SLD10-150-A3	215.4	150	123	27	10	10	10	35	63	10	17	29.5	M5*4*0.5P*H2.5	3°	5	
-200-A3	265.4	200	173	27	10	10	10	35	63	10	17	34.5	M5*4*0.5P*H2.5	3°	5	

规格说明:

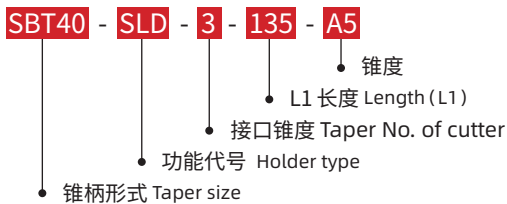

SLD 侧固式刀柄延长杆专用螺丝:

SLD side fixed extension rod special screw

规格 Model	使用孔径 D Using aperture
M3.5 × 3 × P0.35 × T6	D3
M4 × 2.8 × P0.5 × T8	D4
M4 × 4 × P0.5 × T8	D4
M5 × 3.5 × P0.5 × T10	D6
M5 × 5 × P0.5 × T10	D6 D8 D10
M6 × 4 × P0.75 × T15	D12
M6 × 6 × P0.75 × T15	D12
M8 × 5 × P0.75 × L4	D16 D20
M4 × 2.8 × P0.5 × H2	D4
M5 × 4 × P0.5 × H2.5	D6 D8 D10
M6 × 4 × P0.75 × H3	D12
M6 × 5 × P0.75 × H3	D12

备注: 梅花扳手 "T", 六角扳手 "H"

六角扳手: 更大的锁紧力 (需注意控制尺寸)

梅花扳手: 使用更方便

D
SBT SHANK SYSTEMS
SBT 刀柄系列

·SBT50-SLD 小径侧固刀柄

SBT40-SLD SMALL DIAMETER SIDE LOCK TOOL HOLDER

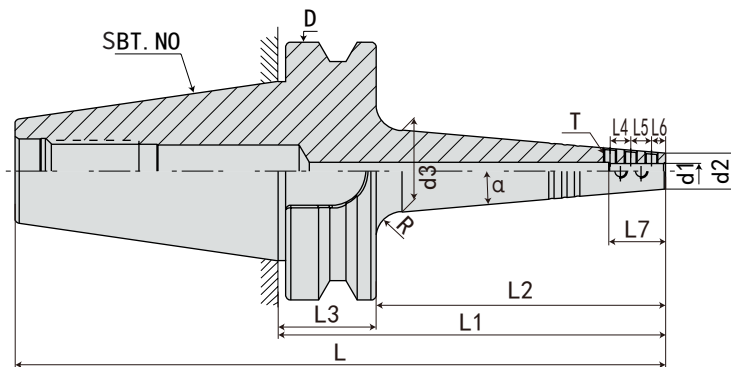
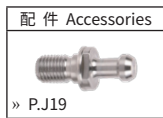

规格 Model	L	L1	L2	L3	L4	L5	L6	L7	D	d1	d2	d3	T	α	R	重量 KGS
SBT50- SLD4-150-A5	251.8	150	112	38	7	7	6	20	100	4	12	30	M4*2.8*0.5P*H2	5°	10	
-200-A5	301.8	200	162	38	7	7	6	20	100	4	12	38.5	M4*2.8*0.5P*H2	5°	10	
-250-A5	351.8	250	212	38	7	7	6	20	100	4	12	47.5	M4*2.8*0.5P*H2	5°	10	
-300-A5	401.8	300	262	38	7	7	6	20	100	4	12	56	M4*2.8*0.5P*H2	5°	10	
- SLD6-150-A5	251.8	150	112	38	8	8	6	22	100	6	14	32	M5*4*0.5P*H2.5	5°	10	
-200-A5	301.8	200	162	38	8	8	6	22	100	6	14	40.5	M5*4*0.5P*H2.5	5°	10	
-250-A5	351.8	250	212	38	8	8	6	22	100	6	14	49.5	M5*4*0.5P*H2.5	5°	10	
-300-A5	401.8	300	262	38	8	8	6	22	100	6	14	58	M5*4*0.5P*H2.5	5°	10	
- SLD8-150-A5	251.8	150	112	38	10	10	7	27	100	8	16	34	M5*4*0.5P*H2.5	5°	10	
-200-A5	301.8	200	162	38	10	10	7	27	100	8	16	42.5	M5*4*0.5P*H2.5	5°	10	
-250-A5	351.8	250	212	38	10	10	7	27	100	8	16	51.5	M5*4*0.5P*H2.5	5°	10	
-300-A5	401.8	300	262	38	10	10	7	27	100	8	16	60	M5*4*0.5P*H2.5	5°	10	
-SLD10-150-A5	251.8	150	112	38	10	10	10	35	100	10	18	36	M5*4*0.5P*H2.5	5°	10	
-200-A5	301.8	200	162	38	10	10	10	35	100	10	18	44.5	M5*4*0.5P*H2.5	5°	10	
-250-A5	351.8	250	212	38	10	10	10	35	100	10	18	53.5	M5*4*0.5P*H2.5	5°	10	
-300-A5	401.8	300	262	38	10	10	10	35	100	10	18	62	M5*4*0.5P*H2.5	5°	10	
-SLD12-150-A5	251.8	150	112	38	10	10	10	45	100	12	22	40	M6*5*0.75P*H3	5°	10	
-200-A5	301.8	200	162	38	10	10	10	45	100	12	22	48.5	M6*5*0.75P*H3	5°	10	
-250-A5	351.8	250	212	38	10	10	10	45	100	12	22	57.5	M6*5*0.75P*H3	5°	10	
-300-A5	401.8	300	262	38	10	10	10	45	100	12	22	66	M6*5*0.75P*H3	5°	10	
-SLD16-150-A5	251.8	150	112	38	12	12	10	50	100	16	26	44	M8*5*0.75P*L4	5°	10	
-200-A5	301.8	200	162	38	12	12	10	50	100	16	26	52.5	M8*5*0.75P*L4	5°	10	
-250-A5	351.8	250	212	38	12	12	10	50	100	16	26	61.5	M8*5*0.75P*L4	5°	10	
-300-A5	401.8	300	262	38	12	12	10	50	100	16	26	70	M8*5*0.75P*L4	5°	10	
-SLD20-150-A5	251.8	150	112	38	12	12	10	55	100	20	30	48	M8*5*0.75P*L4	5°	10	
-200-A5	301.8	200	162	38	12	12	10	55	100	20	30	56.5	M8*5*0.75P*L4	5°	10	
-250-A5	351.8	250	212	38	12	12	10	55	100	20	30	65.5	M8*5*0.75P*L4	5°	10	
-300-A5	401.8	300	262	38	12	12	10	55	100	20	30	74	M8*5*0.75P*L4	5°	10	

规格说明:

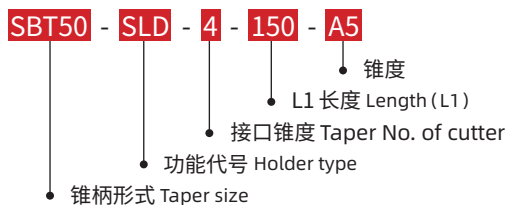

备注：梅花扳手“T”，六角扳手“H”
六角扳手：更大的锁紧力（需注意控制尺寸）
梅花扳手：使用更方便

SLD 侧固式刀柄延长杆专用螺丝:

SLD side fixed extension rod special screw

规格 Model	使用孔径 D Using aperture
M3.5 × 3 × P0.35 × T6	D3
M4 × 2.8 × P0.5 × T8	D4
M4 × 4 × P0.5 × T8	D4
M5 × 3.5 × P0.5 × T10	D6
M5 × 5 × P0.5 × T10	D6 D8 D10
M6 × 4 × P0.75 × T15	D12
M6 × 6 × P0.75 × T15	D12
M8 × 5 × P0.75 × L4	D16 D20
M4 × 2.8 × P0.5 × H2	D4
M5 × 4 × P0.5 × H2.5	D6 D8 D10
M6 × 4 × P0.75 × H3	D12
M6 × 5 × P0.75 × H3	D12

·SBT50-SLD 小径侧固刀柄

SBT40-SLD SMALL DIAMETER SIDE LOCK TOOL HOLDER

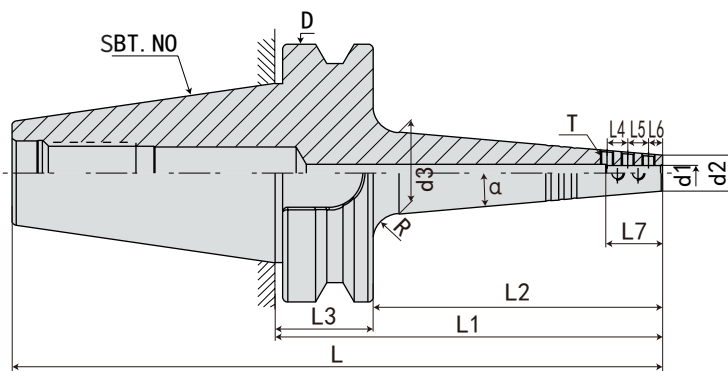
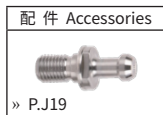

规格 Model	L	L1	L2	L3	L4	L5	L6	L7	D	d1	d2	d3	T	α	R	重量 KGS
SBT50- SLD6-150-A3	251.8	150	112	38	8	8	6	22	100	6	14	25	M5*4*0.5P*H2.5	3°	10	
-200-A3	301.8	200	162	38	8	8	6	22	100	6	14	30	M5*4*0.5P*H2.5	3°	10	
-250-A3	351.8	250	212	38	8	8	6	22	100	6	14	35	M5*4*0.5P*H2.5	3°	10	
-300-A3	401.8	300	262	38	8	8	6	22	100	6	14	40	M5*4*0.5P*H2.5	3°	10	
- SLD8-150-A3	251.8	150	112	38	10	10	7	27	100	8	16	27	M5*4*0.5P*H2.5	3°	10	
-200-A3	301.8	200	162	38	10	10	7	27	100	8	16	32	M5*4*0.5P*H2.5	3°	10	
-250-A3	351.8	250	212	38	10	10	7	27	100	8	16	37	M5*4*0.5P*H2.5	3°	10	
-300-A3	401.8	300	262	38	10	10	7	27	100	8	16	42	M5*4*0.5P*H2.5	3°	10	
-SLD10-150-A3	251.8	150	112	38	10	10	10	35	100	10	18	29	M5*4*0.5P*H2.5	3°	10	
-200-A3	301.8	200	162	38	10	10	10	35	100	10	18	34	M5*4*0.5P*H2.5	3°	10	
-250-A3	351.8	250	212	38	10	10	10	35	100	10	18	39	M5*4*0.5P*H2.5	3°	10	
-300-A3	401.8	300	262	38	10	10	10	35	100	10	18	44	M5*4*0.5P*H2.5	3°	10	
-SLD12-150-A3	251.8	150	112	38	10	10	10	45	100	12	22	33	M6*5*0.75P*H3	3°	10	
-200-A3	301.8	200	162	38	10	10	10	45	100	12	22	38	M6*5*0.75P*H3	3°	10	
-250-A3	351.8	250	212	38	10	10	10	45	100	12	22	43	M6*5*0.75P*H3	3°	10	
-300-A3	401.8	300	262	38	10	10	10	45	100	12	22	48	M6*5*0.75P*H3	3°	10	

规格说明:

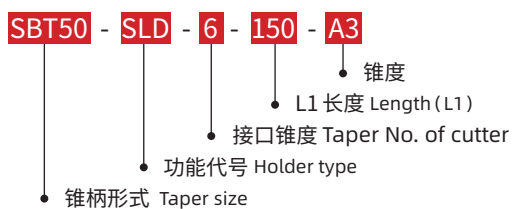

SLD 侧固式刀柄延长杆专用螺丝:

SLD side fixed extension rod special screw

规格 Model	使用孔径 D Using aperture
M3.5 × 3 × P0.35 × T6	D3
M4 × 2.8 × P0.5 × T8	D4
M4 × 4 × P0.5 × T8	D4
M5 × 3.5 × P0.5 × T10	D6
M5 × 5 × P0.5 × T10	D6 D8 D10
M6 × 4 × P0.75 × T15	D12
M6 × 6 × P0.75 × T15	D12
M8 × 5 × P0.75 × L4	D16 D20
M4 × 2.8 × P0.5 × H2	D4
M5 × 4 × P0.5 × H2.5	D6 D8 D10
M6 × 4 × P0.75 × H3	D12
M6 × 5 × P0.75 × H3	D12

备注：梅花扳手“T”，六角扳手“H”

六角扳手：更大的锁紧力（需注意控制尺寸）

梅花扳手：使用更方便

·SBT-SCA 侧铣刀柄

SBT-SCA SIDE CUTTER ADAPTET

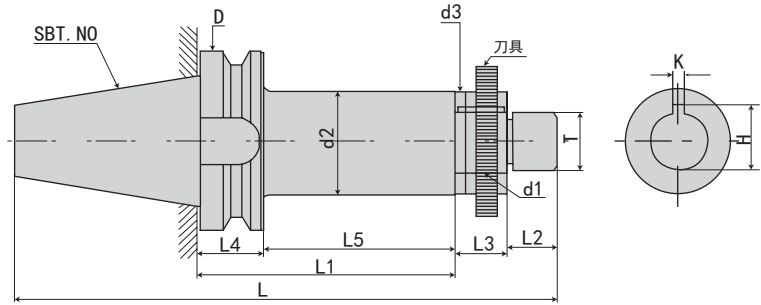

规格 Model	L	L1	L2	L3	L4	L5	D	d1	d2	d3	K	H	T	重量 KGS
SBT30-SCA10- 60	108.4	60	12	30	22	39	46	10	18	18	-	-	M8*1.25P	
-SCA16- 60	108.4	60	16	30	22	39	46	16	26	26	4	17.7	M14*1.5P	
-SCA22- 60	108.4	60	22	30	22	39	46	22	34	34	6	24.3	M20*1.5P	
-SCA27- 75	123.4	75	28	30	22	54	46	27	41	41	7	30	M24*1.5P	
SBT40-SCA16- 60	171.4	60	16	30	27	34	63	16	26	26	4	17.7	M14*1.5P	
-SCA22- 75	192.4	75	22	30	27	49	63	22	34	34	6	24.3	M20*1.5P	
-120	237.4	120	22	30	27	94	63	22	34	34	6	24.3	M20*1.5P	
-SCA27- 75	198.4	75	28	30	27	49	63	27	41	41	7	30	M24*1.5P	
-120	243.4	120	28	30	27	94	63	27	41	41	7	30	M24*1.5P	
-SCA32- 90	217.4	90	32	30	27	64	63	32	47	47	8	35	M30*1.5P	
-180	307.4	180	32	30	27	154	63	32	47	47	8	35	M30*1.5P	
SBT50-SCA22- 90	243.8	90	22	30	38	53.5	100	22	34	34	6	24.3	M20*1.5P	
-135	288.8	135	22	30	38	98.5	100	22	34	34	6	24.3	M20*1.5P	
-SCA27- 90	249.8	90	28	30	38	53.5	100	27	41	41	7	30	M24*1.5P	
-135	294.8	135	28	30	38	98.5	100	27	41	41	7	30	M24*1.5P	
-SCA32- 90	253.8	90	32	30	38	53.5	100	32	47	47	8	35	M30*1.5P	
-135	398.8	135	32	30	38	98.5	100	32	47	47	8	35	M30*1.5P	
-SCA40- 90	261.8	90	40	30	38	53.5	100	40	55	55	10	43.7	M36*2.0P	
-135	306.8	135	40	30	38	98.5	100	40	55	55	10	43.7	M36*2.0P	

特点:

注:

- ◎ 割槽刀，三面刃铣刀等使用时，为使用刀具与刀杆紧密接触，请调整垫片
- ◎ 选购刀柄，根据加工需要请确认装锯片卡位大小。不附带拉钉
- ◎ 拉钉须另行购买

Features:

- ◎ Shears the trough knife, when uses and so on three edge milling cutters, is uses the cutting tool and the cutter bar contacts closely, requests transfer the entire filling piece.
- ◎ Selects and purchases the hilt, according to the processing needs please to confirm that installs the saw blade jamming size. Does not supplement the puller bolt to select.
- ◎ The pull stud must purchase alone.

规格说明:

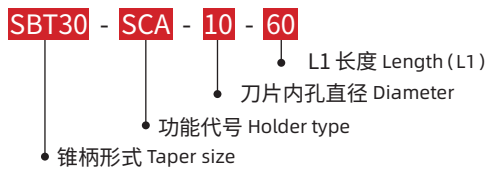

·SBT30-M 螺纹连接刀柄（直柄）

SBT30-M THERADED CHUCK

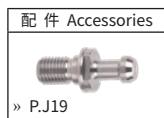
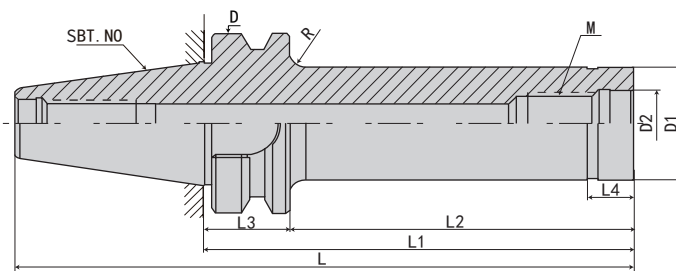

规格 Model	L	L1	L2	L3	L4	D	D1	D2	M	R	重量 KGS
SBT30-M08- 60	108.4	60	38	22	12	46	15.4	8.5	M8*1.25P	4	
- 90	138.4	90	68	22	12	46	15.4	8.5	M8*1.25P	4	0.5
-110	158.4	110	88	22	12	46	15.4	8.5	M8*1.25P	4	
-M10- 60	108.4	60	38	22	12	46	19	10.5	M10*1.5P	4	
- 90	138.4	90	68	22	12	46	19	10.5	M10*1.5P	4	0.5
-110	158.4	110	88	22	12	46	19	10.5	M10*1.5P	4	
-M12- 60	108.4	60	38	22	12	46	24	12.5	M12*1.75P	4	
- 90	138.4	90	68	22	12	46	24	12.5	M12*1.75P	4	0.6
-110	158.4	110	88	22	12	46	24	12.5	M12*1.75P	4	
-M16- 60	108.4	60	38	22	12	46	29	17	M16*2.0P	4	
- 90	138.4	90	68	22	12	46	29	17	M16*2.0P	4	0.7
-110	158.4	110	88	22	12	46	29	17	M16*2.0P	4	

规格说明:



·SBT40-M 螺纹连接刀柄（直柄）

SBT40-M THERADED CHUCK

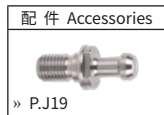
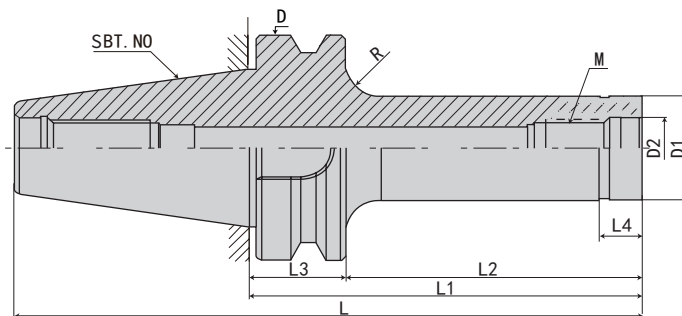

规格 Model	L	L1	L2	L3	L4	D	D1	D2	M	R	重量 KGS
SBT40-M08- 60	125.4	60	33	27	12	63	15.4	8.5	M8*1.25P	10	1.1
- 90	155.4	90	63	27	12	63	15.4	8.5	M8*1.25P	10	1.2
-110	175.4	110	83	27	12	63	15.4	8.5	M8*1.25P	10	1.2
-M10- 60	125.4	60	33	27	12	63	19	10.5	M10*1.5P	10	1.1
- 90	155.4	90	63	27	12	63	19	10.5	M10*1.5P	10	1.1
-110	175.4	110	83	27	12	63	19	10.5	M10*1.5P	10	1.2
-M12- 60	125.4	60	33	27	12	63	24	12.5	M12*1.75P	10	1.2
- 90	155.4	90	63	27	12	63	24	12.5	M12*1.75P	10	1.3
-110	175.4	110	83	27	12	63	24	12.5	M12*1.75P	10	1.3
-M16- 60	125.4	60	33	27	12	63	29	17	M16*2.0P	10	1.2
- 90	155.4	90	63	27	12	63	29	17	M16*2.0P	10	1.3
-110	175.4	110	83	27	12	63	29	17	M16*2.0P	10	1.4

规格说明:

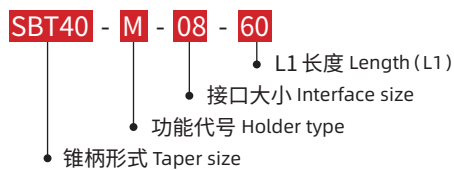

·SBT50-M 螺纹连接刀柄 (直柄)

SBT50-M THERADED CHUCK

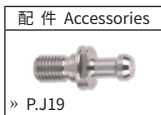
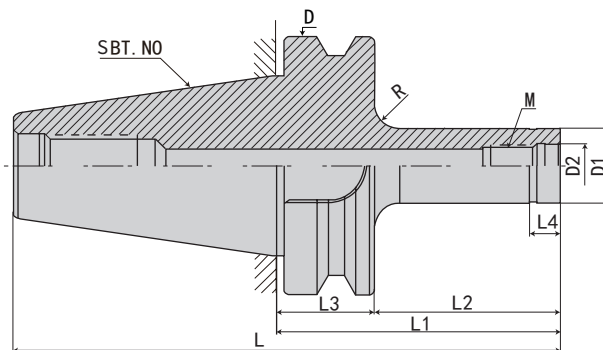

规格 Model	L	L1	L2	L3	L4	D	D1	D2	M	R	重量 KGS
SBT50-M08- 60	161.8	60	22	38	12	100	15.4	8.5	M8*1.25P	10	
- 90	191.8	90	52	38	12	100	15.4	8.5	M8*1.25P	10	3.8
-110	211.8	110	72	38	12	100	15.4	8.5	M8*1.25P	10	3.8
-M10- 60	161.8	60	22	38	12	100	19	10.5	M10*1.5P	10	
- 90	191.8	90	52	38	12	100	19	10.5	M10*1.5P	10	3.8
-110	211.8	110	72	38	12	100	19	10.5	M10*1.5P	10	3.8
-M12- 60	161.8	60	22	38	12	100	24	12.5	M12*1.75P	10	
- 90	191.8	90	52	38	12	100	24	12.5	M12*1.75P	10	3.9
-110	211.8	110	72	38	12	100	24	12.5	M12*1.75P	10	3.9
-M16- 60	161.8	60	22	38	12	100	29	17	M16*2.0P	10	3.9
- 90	191.8	90	52	38	12	100	29	17	M16*2.0P	10	3.9
-110	211.8	110	72	38	12	100	29	17	M16*2.0P	10	3.9

规格说明:

SBT50 - M - 08 - 60

- L1 长度 Length (L1)
- 接口大小 Interface size
- 功能代号 Holder type
- 锥柄形式 Taper size

·SBT30-M 螺纹连接刀柄（斜柄）

SBT30-M THERADED CHUCK

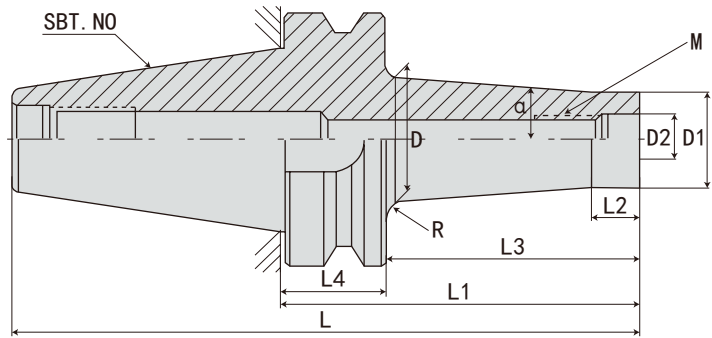

规格 Model	L	L1	L2	L3	L4	D	D1	D2	M	α	R	重量 KGS
SBT30-M08-60-A5	108.4	60	12	39	22	19.5	15.4	8.5	M8*1.25P	5°	4	
-90-A5	138.4	90	12	69	22	24.5	15.4	8.5	M8*1.25P	5°	4	
-M10-60-A4	108.4	60	12	39	22	22	19	10.5	M10*1.5P	4°	4	
-90-A4	138.4	90	12	69	22	26	19	10.5	M10*1.5P	4°	4	
-M12-60-A4	108.4	60	12	39	22	27	24	12.5	M12*1.75P	4°	4	
-90-A4	138.4	90	12	69	22	31.5	24	12.5	M12*1.75P	4°	2	
-M16-60-A4	108.4	60	12	39	22	32.5	29	17	M16*2.0P	4°	2	
-90-A4	138.4	90	12	69	22	36.5	29	17	M16*2.0P	4°	2	

规格说明:

SBT30 - M - 08 - 60 - A5

- 单边锥度 Unilateral taper
- L1 长度 Length (L1)
- 接口大小 Interface size
- 功能代号 Holder type
- 锥柄形式 Taper size

·SBT40-M 螺纹连接刀柄 (斜柄)

SBT40-M THERADED CHUCK

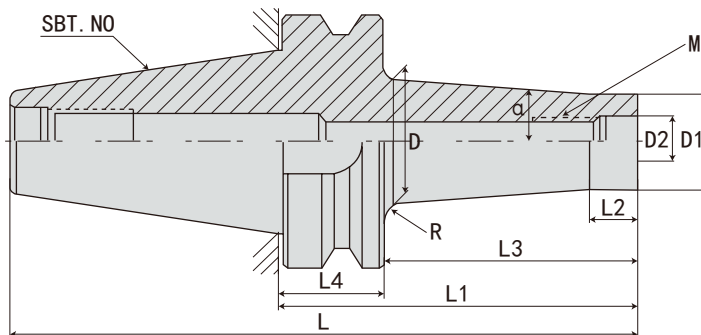
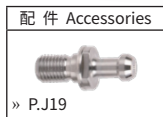

规格 Model	L	L1	L2	L3	L4	D	D1	D2	M	α	R	重量 KGS
SBT40-M08- 60-A5	125.4	60	12	34	27	18	15.4	8.5	M8*1.25P	5°	5	
- 90-A5	155.4	90	12	64	27	23.5	15.4	8.5	M8*1.25P	5°	5	
-110-A5	175.4	110	12	84	27	27	15.4	8.5	M8*1.25P	5°	5	
-150-A5	215.4	150	12	124	27	34	15.4	8.5	M8*1.25P	5°	5	
-200-A5	265.4	200	12	174	27	42.5	15.4	8.5	M8*1.25P	5°	5	
-M10- 60-A4	125.4	60	12	34	27	21.5	19	10.5	M10*1.5P	4°	5	
- 90-A4	155.4	90	12	64	27	25.5	19	10.5	M10*1.5P	4°	5	
-110-A4	175.4	110	12	84	27	28.5	19	10.5	M10*1.5P	4°	5	
-150-A4	215.4	150	12	124	27	34	19	10.5	M10*1.5P	4°	5	
-200-A4	265.4	200	12	174	27	41	19	10.5	M10*1.5P	4°	5	
-M12- 60-A4	125.4	60	12	34	27	25.5	23	12.5	M12*1.75P	4°	5	
- 90-A4	155.4	90	12	64	27	29.5	23	12.5	M12*1.75P	4°	5	
-110-A4	175.4	110	12	84	27	32.5	23	12.5	M12*1.75P	4°	5	
-135-A4	200.4	135	12	109	27	36	23	12.5	M12*1.75P	4°	5	
-150-A4	215.4	150	12	124	27	38	23	12.5	M12*1.75P	4°	5	
-200-A4	265.4	200	12	174	27	45	23	12.5	M12*1.75P	4°	5	
-M16- 60-A4	125.4	60	12	34	27	31	28.8	17	M16*2.0P	4°	5	
- 90-A4	155.4	90	12	64	27	35.5	28.8	17	M16*2.0P	4°	5	
-110-A4	175.4	110	12	84	27	38	28.8	17	M16*2.0P	4°	5	
-135-A4	200.4	135	12	109	27	41.5	28.8	17	M16*2.0P	4°	5	
-150-A4	215.4	150	12	124	27	43.5	28.8	17	M16*2.0P	4°	5	
-200-A4	265.4	200	12	174	27	50.5	28.8	17	M16*2.0P	4°	5	

规格说明:

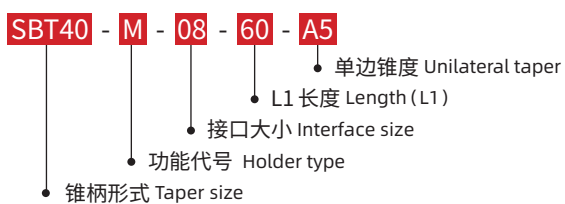

·SBT50-M 螺纹连接刀柄 (斜柄)

SBT50-M THERADED CHUCK

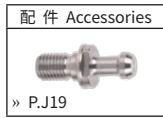
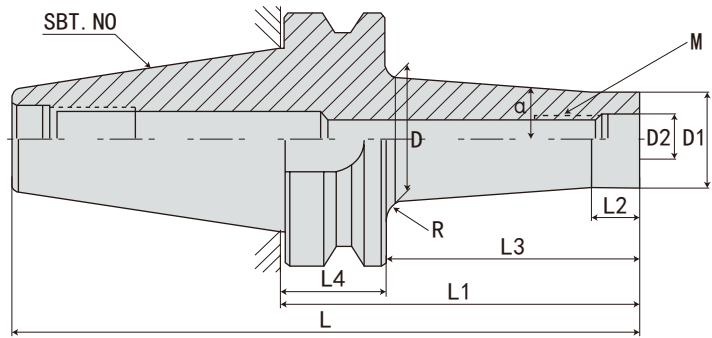

规格 Model	L	L1	L2	L3	L4	D	D1	D2	M	α	R	重量 KGS
SBT50-M08- 60-A5	161.8	60	12	23.5	38	17.5	15.4	8.5	M8*1.25P	5°	10	
- 90-A5	191.8	90	12	53.5	38	20.5	15.4	8.5	M8*1.25P	5°	10	
-110-A5	211.8	110	12	73.5	38	24	15.4	8.5	M8*1.25P	5°	10	
-150-A5	251.8	150	12	113.5	38	31	15.4	8.5	M8*1.25P	5°	10	
-200-A5	301.8	200	12	163.5	38	40	15.4	8.5	M8*1.25P	5°	10	
-250-A5	351.8	250	12	213.5	38	48.5	15.4	8.5	M8*1.25P	5°	10	
-300-A5	401.8	300	12	263.5	38	57.5	15.4	8.5	M8*1.25P	5°	10	
-M10- 60-A4	161.8	60	12	23.5	38	20.5	19	10.5	M10*1.5P	4°	10	
- 90-A4	191.8	90	12	53.5	38	23	19	10.5	M10*1.5P	4°	10	
-110-A4	211.8	110	12	73.5	38	26	19	10.5	M10*1.5P	4°	10	
-150-A4	251.8	150	12	113.5	38	31.5	19	10.5	M10*1.5P	4°	10	
-200-A4	301.8	200	12	163.5	38	38.5	19	10.5	M10*1.5P	4°	10	
-250-A4	351.8	250	12	213.5	38	45.5	19	10.5	M10*1.5P	4°	10	
-300-A4	401.8	300	12	263.5	38	52.5	19	10.5	M10*1.5P	4°	10	
-M12- 60-A4	161.8	60	12	23.5	38	25.5	24	12.5	M12*1.75P	4°	10	
- 90-A4	191.8	90	12	53.5	38	28	24	12.5	M12*1.75P	4°	10	
-110-A4	211.8	110	12	73.5	38	31	24	12.5	M12*1.75P	4°	10	
-135-A4	236.8	135	12	98.5	38	34.5	24	12.5	M12*1.75P	4°	10	
-150-A4	251.8	150	12	113.5	38	36.5	24	12.5	M12*1.75P	4°	10	
-200-A4	301.8	200	12	163.5	38	43.5	24	12.5	M12*1.75P	4°	10	
-250-A4	351.8	250	12	213.5	38	50.5	24	12.5	M12*1.75P	4°	10	
-300-A4	401.8	300	12	263.5	38	57.5	24	12.5	M12*1.75P	4°	10	
-M16- 60-A4	161.8	60	12	23.5	38	30.5	29	17	M16*2.0P	4°	10	
- 90-A4	191.8	90	12	53.5	38	33	29	17	M16*2.0P	4°	10	
-110-A4	211.8	110	12	73.5	38	36	29	17	M16*2.0P	4°	10	
-135-A4	236.8	135	12	98.5	38	39.5	29	17	M16*2.0P	4°	10	
-150-A4	251.8	150	12	113.5	38	41.5	29	17	M16*2.0P	4°	10	
-200-A4	301.8	200	12	163.5	38	48.5	29	17	M16*2.0P	4°	10	
-250-A4	351.8	250	12	213.5	38	55.5	29	17	M16*2.0P	4°	10	
-300-A4	401.8	300	12	263.5	38	62.5	29	17	M16*2.0P	4°	10	

规格说明:

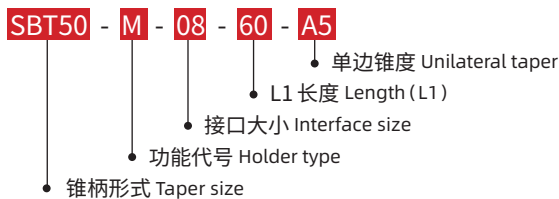

·SBT-MOD 模块刀柄

SBT-MOD MODULAR TOOL HOLDER

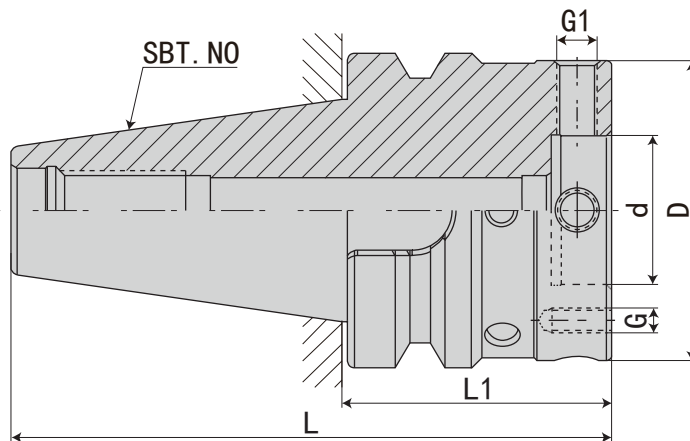

规格 Model	L	L1	D	d	G1	G	重量 KGS
SBT30-MOD060-040	88.4	40	60	30	M8*1.0P	M5*0.8P	0.7
-MOD070-040	88.4	40	70	35	M8*1.0P	M6*1.0P	0.8
SBT40-MOD060-055	120.4	55	60	30	M8*1.0P	M5*0.8P	1.5
-MOD070-055	120.4	55	70	35	M8*1.0P	M6*1.0P	1.6
-MOD080-065	130.4	65	80	40	M8*1.0P	M6*1.0P	2
-MOD100-070	135.4	70	100	50	M10*1.0P	M8*1.25P	2.6
SBT45-MOD060-065	147.8	65	60	30	M8*1.0P	M5*0.8P	3
-MOD070-065	147.8	65	70	35	M8*1.0P	M6*1.0P	3.1
-MOD080-065	147.8	65	80	40	M8*1.0P	M6*1.0P	3.3
-MOD100-075	157.8	75	100	50	M10*1.0P	M8*1.25P	3.5
-MOD117-075	157.8	75	117	60	M10*1.0P	M8*1.25P	4.4
SBT50-MOD060-070	171.8	70	60	30	M8*1.0P	M5*0.8P	4.8
-MOD070-070	171.8	70	70	35	M8*1.0P	M6*1.0P	4.9
-MOD080-070	171.8	70	80	40	M8*1.0P	M6*1.0P	5.1
-MOD100-070	171.8	70	100	50	M10*1.0P	M8*1.25P	5.3
-MOD117-080	181.8	80	117	60	M10*1.0P	M8*1.25P	6.3
-MOD140-080	181.8	80	140	80	M10*1.0P	M8*1.25P	6.6

规格说明:

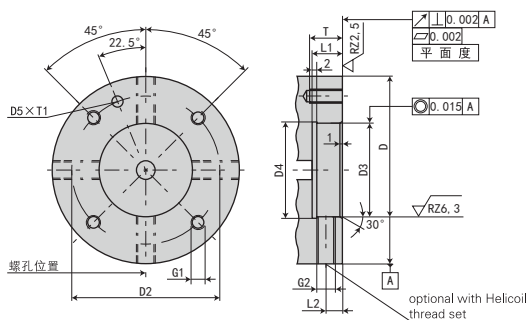
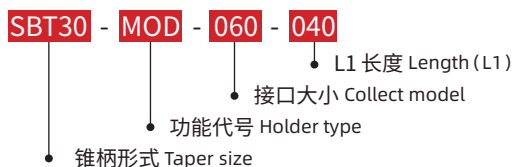

Nominal size module diameter D	32	40	50	63	80	100	125	160
D2+/-0.1	44	53	63	79	96	119	150	185
D3F8	30	35	40	50	60	80	100	120
D4	31	36	41	51	61	81	101	121
D5	4.5	5.0	5.0	5.0	6.0	6.0	6.0	6.0
L1	12	12	12	14	14	14	24	37
L2	7	7	7	8	8	8	8	8
G1	M5	M6	M6	M8	M8	M10	M12	M12
G2	M8*1	M8*1	M8*1	M10*1	M10*1	M10*1	M10*1	M10*1
T	11	14	14	15	15	18	25	25
T1+0.5	3	3.5	3.5	3.5	4.5	4.5	4.5	4.5

D
SBT SHANK SYSTEMS
SBT 刀柄系列

·MOD 法兰盘 MOD FLANGE PLATE

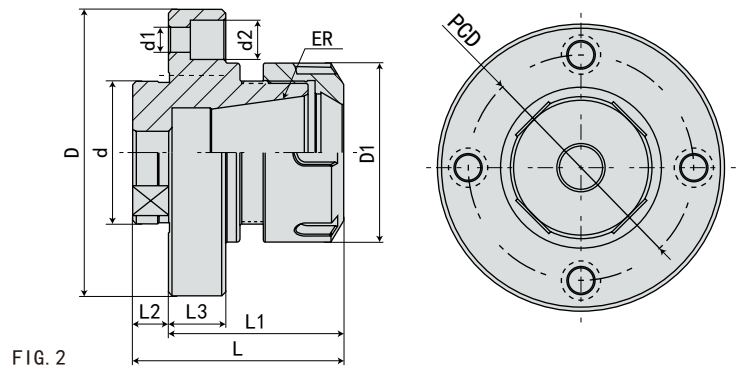
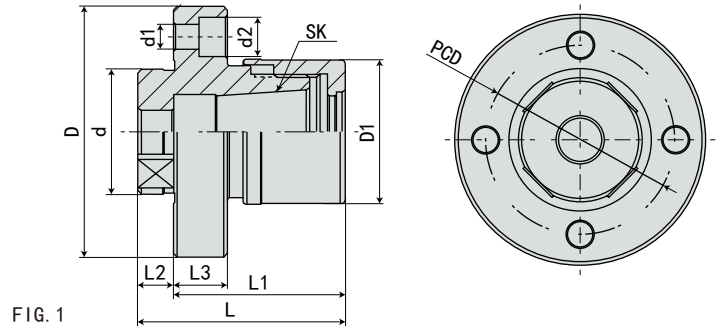

规格 Model	D	D1	d	d1	d2	L	L1	L2	L3	PCD	FIG
MOD060-GSK16-48	60	40	30	6	9	58	48	10	15	44	1
MOD070-GSK16-48	70	40	35	7	11	58	48	10	15	53	1
MOD080-GSK16-49	80	40	40	7	11	59	49	10	16	63	1
MOD080-ER32-49	80	50	40	7	11	59	49	10	16	63	2
MOD100-ER40-63	100	63	50	9	14	75	63	12	18	79	2

规格说明:



·SBT-MOD 可调精度刀柄 (铰刀专用)

SBT-MOD ADJUSTABLE CHUCK (REAMER USING)



配件 Accessories

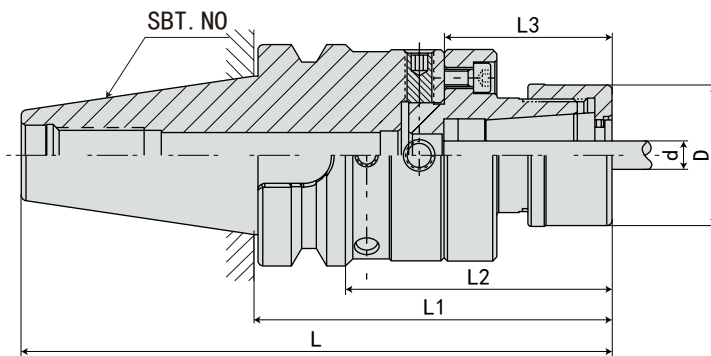

规格 Model	L	L1	L2	L3	D	d 夹持范围 Range	弹性筒夹 Collets
SBT30-MOD060-GSK16- 88	136.4	88	66	48	40	3-16mm	GSK16
-MOD070-GSK16- 88	136.4	88	66	48	40	3-16mm	GSK16
SBT40-MOD060-GSK16-103	168.4	103	76	48	40	3-16mm	GSK16
-MOD070-GSK16-103	168.4	103	76	48	40	3-16mm	GSK16
-MOD080- ER32-114	179.4	114	87	49	50	2-20mm	ER32
-MOD080-GSK16-114	179.4	114	87	49	40	3-16mm	GSK16
-MOD100- ER40-133	198.4	133	106	63	63	2-26mm	ER40
SBT50-MOD060-GSK16-118	219.8	118	80	48	40	3-16mm	GSK16
-MOD070-GSK16-118	219.8	118	80	48	40	3-16mm	GSK16
-MOD080- ER32-119	220.8	119	81	49	50	2-20mm	ER32
-MOD080-GSK16-119	220.8	119	81	49	40	3-16mm	GSK16
-MOD100- ER40-133	234.8	133	95	63	63	2-26mm	ER40

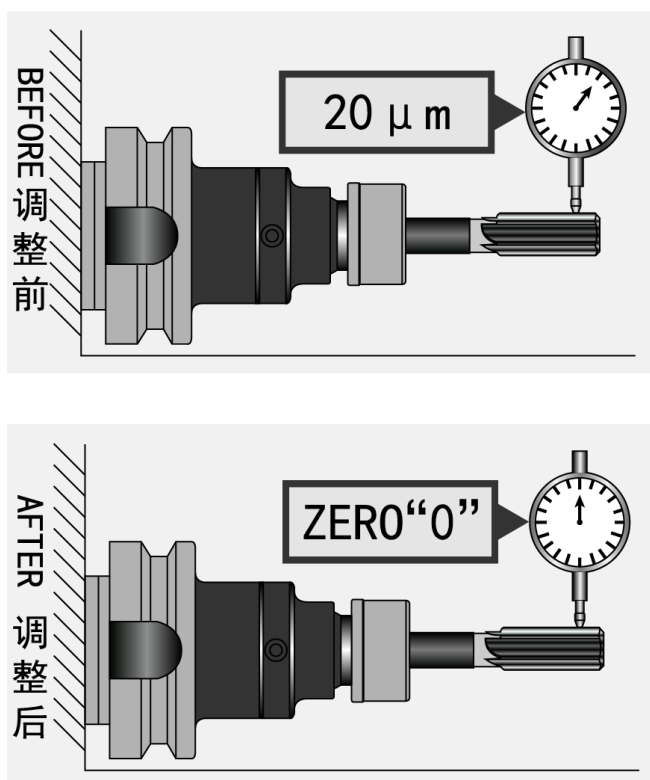
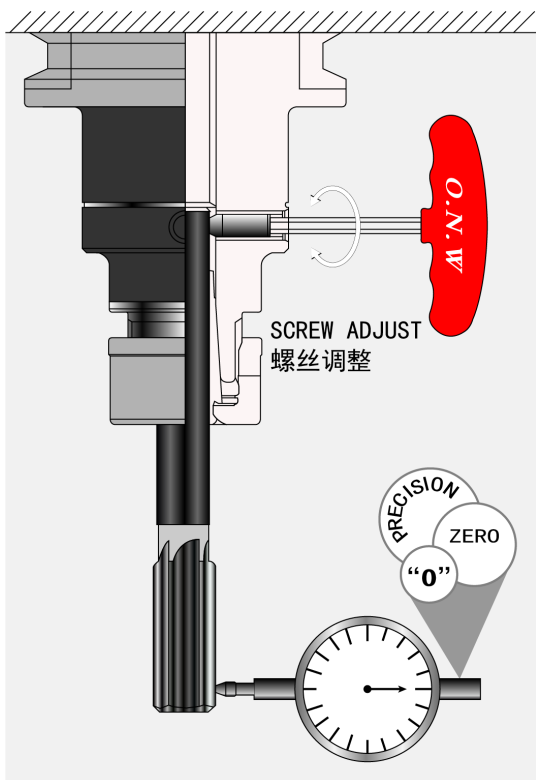

特点:

- ◎ 刀尖位置可调至 "0" 位置
- ◎ 机械主轴、夹头、刀具的累计误差值可一次调整修正

Features:

- ◎ The tool tip position can be adjusted as "0" position.
- ◎ The accumulated error value of the spindle, the chuck, and the tool can all be adjusted and corrected at the same time.

规格说明:

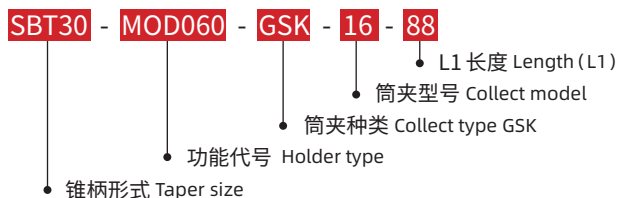

·SBT- 基础柄刀柄

SBT SEMI-FINISHED TOOL HOLDER

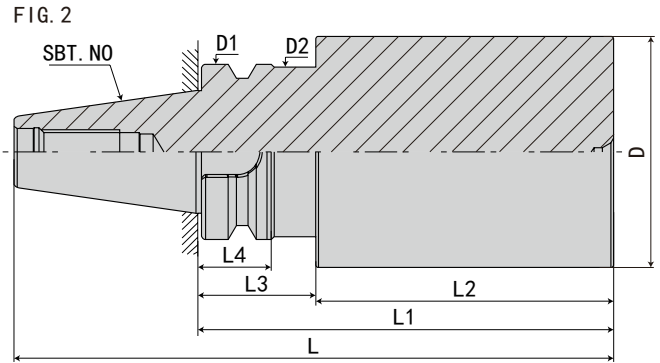
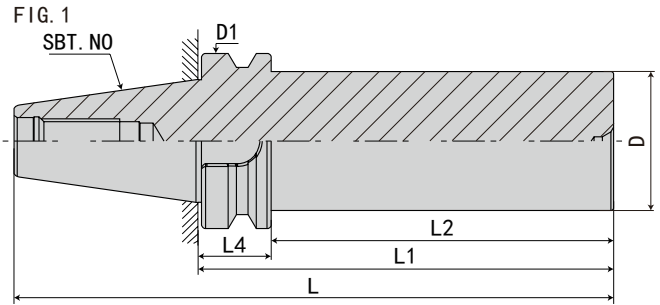
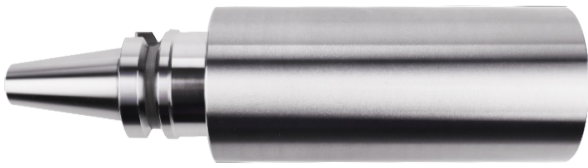

规格 Model	L	L1	L2	L3	L4	D	D1	D2	FIG	重量 KGS
SBT30- D50-100	148.4	100	68	32	22	50	46	44	2	
-125	173.4	125	93	32	22	50	46	44	2	
-150	198.4	150	118	32	22	50	46	44	2	
- D63-100	148.4	100	68	32	22	63	46	44	2	
-125	173.4	125	93	32	22	63	46	44	2	
-150	198.4	150	118	32	22	63	46	44	2	
- D83-100	148.4	100	68	32	22	83	46	44	2	
-125	173.4	125	93	32	22	83	46	44	2	
- D102-125	173.4	125	93	32	22	102	46	44	2	
SBT40- D50-100	165.4	100	73	-	27	50	63	-	1	
-150	215.4	150	123	-	27	50	63	-	1	
-200	265.4	200	173	-	27	50	63	-	1	
- D63-100	165.4	100	63	37	27	63	63	61	2	
-150	215.4	150	113	37	27	63	63	61	2	
-200	265.4	200	163	37	27	63	63	61	2	
-250	315.4	250	213	37	27	63	63	61	2	
- D83-100	165.4	100	63	37	27	83	63	61	2	
-150	215.4	150	113	37	27	83	63	61	2	
-200	265.4	200	163	37	27	83	63	61	2	
-250	315.4	250	213	37	27	83	63	61	2	
- D102-150	215.4	150	113	37	27	102	63	61	2	
SBT50-D102-100	201.8	100	52	48	38	102	100	98	2	
-150	251.8	150	102	48	38	102	100	98	2	
-200	301.8	200	152	48	38	102	100	98	2	
-250	351.8	250	202	48	38	102	100	98	2	
-300	401.8	300	252	48	38	102	100	98	2	
- D127-150	251.8	150	102	48	38	127	100	98	2	
-200	301.8	200	152	48	38	127	100	98	2	

规格说明:

SBT30 - D - 50 - 100

- L1 长度 Length (L1)
- 刀杆直径 Diameter
- 功能代号 Holder type
- 锥柄形式 Taper size